

EAN CODE:3276000592303  
3276000592310  
3276000632351  
3276000632375

**FR** Manuel d'Instructions

**ES** Manual de Instrucciones

**PT** Manual de Instruções

**IT** Manuale di Istruzioni

**EL** Εγχειρίδιο Οδηγιών

**PL** Instrukcja Obsługi

**RU** Руководства по  
Эксплуатации

**KZ** Пайдаланушы Нұсқаулығы

**UA** Інструкція з Експлуатації

**RO** Manual de Instrucțiuni

**BR** Manual de Instruções

**EN** Instructions Manual

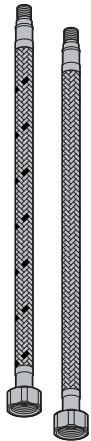
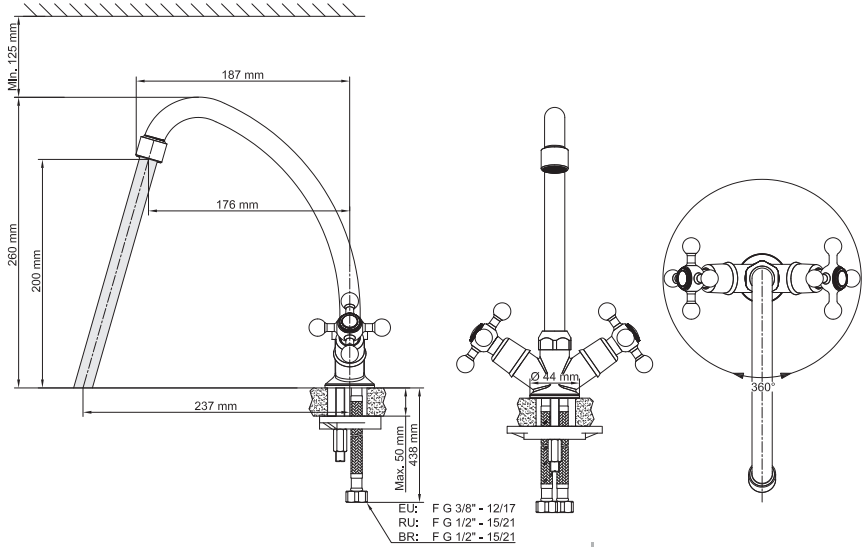

**B**



**C**

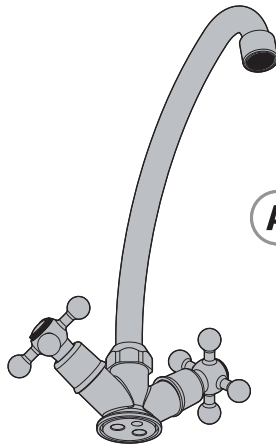

**A**

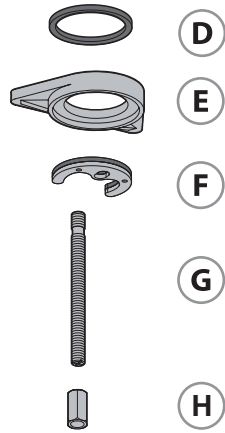

**D**

**E**

**F**

**G**

**H**

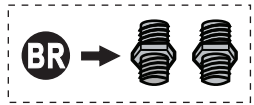

**BR**



11





**FR:** Préparation / **ES:** Preparación / **PT:** Preparação / **IT:** Preparazione / **EL:** Προετοιμασία /  
**PL:** Przygotowanie / **RU:** Подготовка / **KZ:** Дайындау / **UA:** Підготування / **RO:** Pregătire / **BR:** Preparação /  
**EN:** Preparation



**FR:** Montage / **ES:** Montaje / **PT:** Montagem / **IT:** Montaggio / **EL:** Συναρμολόγηση /  
**PL:** Montaż / **RU:** Сборка / **KZ:** Монтаждау / **UA:** Збірка / **RO:** Montaj / **BR:** Montagem /  
**EN:** Assembly



**FR:** Utilisation eau chaude-eau froide/ **ES:** Utilización agua caliente-agua fría/ **PT:** Utilização água quente-água fria/  
**IT:** Uso acqua calda-acqua fredda/ **EL:** Χρήση ζεστού-κρύου νερού/ **PL:** Użytkowanie zimnej wody-gorącej wody/  
**RU:** Використання гарячої води/ **KZ:** Суық және ыстық суды қолдану/ **UA:** води - холодної води/  
**RO:** Utilizare apă caldă-apă rece/ **BR:** Uso de água quente e fria/ **EN:** Using hot and cold water



**FR:** Changement de cartouche/ **ES:** Cambio de cartucho/ **IT:** Cambio cartuccia/ **PT:** Mudança de cartucho/  
**EL:** Αλλαγή φυσιγγίου/ **PL:** Wymiana wkładu / **RU:** Смена картриджа/ **KZ:** Картриджді ауыстыру/  
**UA:** Заміна картриджа/ **RO:** Schimbare cartuş/ **BR:** Substituição de cartucho/ **EN:** Replacing the cartridge



**FR:** Changement de mousseur/ **ES:** Cambio de aireador/ **PT:** Mudança de arejador/ **IT:** Cambio rompigetto/  
**EL:** Αλλαγή αεράτορα / **PL:** Wymiana perlatora / **RU:** Смена аэратора/ **KZ:** Ауақанықтырғышты ауыстыру/  
**UA:** Заміна аератора/ **RO:** Schimbare aerator/ **BR:** Substituição do aerador/ **EN:** Replacing the aerator



**FR:** Changement de flexibles/ **ES:** Cambio de flexibles / **PT:** Mudança de flexíveis/ **IT:** Cambio flessibili/  
**EL:** Αλλαγή λάστιχων/ **PL:** Wymiana wężyków instalacyjnych / **RU:** Смена гибкого шланга для смесителя/  
**UA:** Заміна гнучкого шланга для змішувача/ **KZ:** Қоспалауышқа арналған иілгіш шлангты ауыстыру/  
**RO:** Schimbare furtune flexibile/ **BR:** Substituição das mangueiras/ **EN:** Replacing the hoses





FR: Préparation / ES: Preparación / PT: Preparação / IT: Preparazione / EL: Προετοιμασία /  
PL: Przygotowanie / RU: Подготовка / KZ: Дайындау / UA: Підготування / RO: Pregătire /  
BR: Preparação / EN: Preparation

1

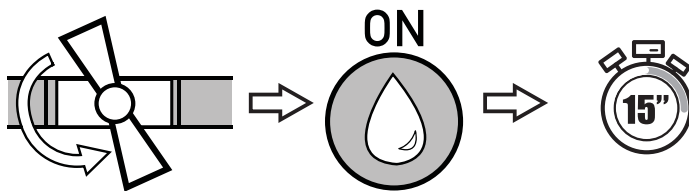

2

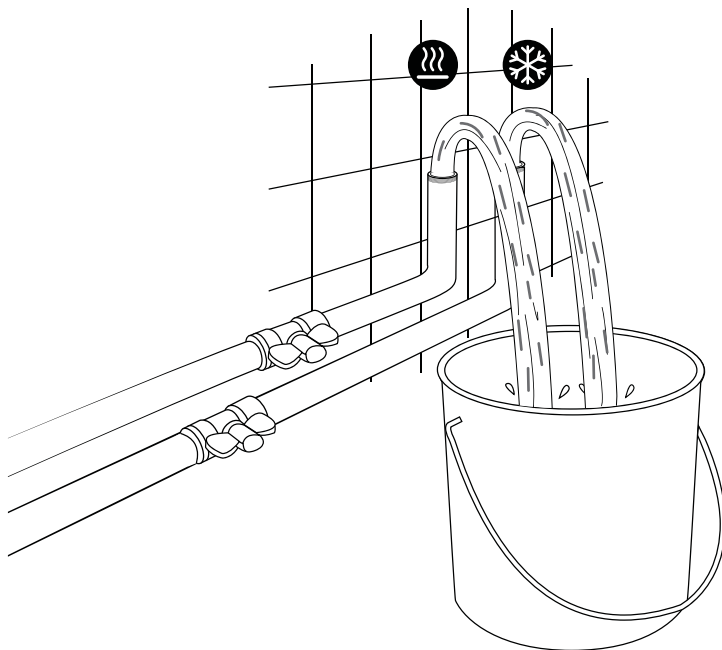

3

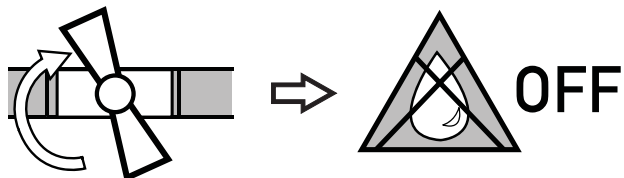

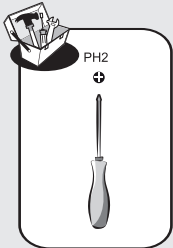
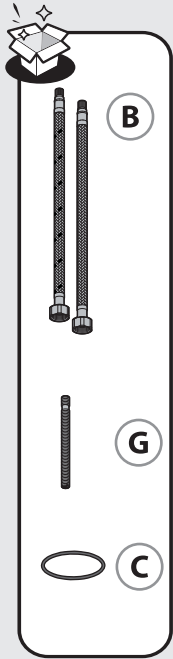

FR: Montage / ES: Montaje / PT: Montagem / IT: Montaggio / EL: Συναρμολόγηση /  
 PL: Montaż / RU: Сборка / KZ: Монтаждау / UA: Збірка / RO: Montaj / BR: Montagem /  
 EN: Assembly

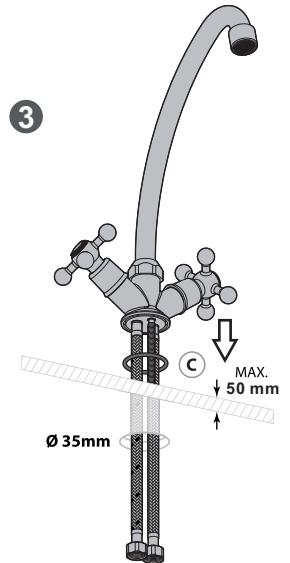
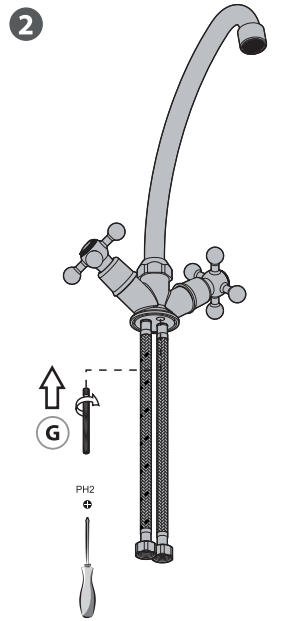
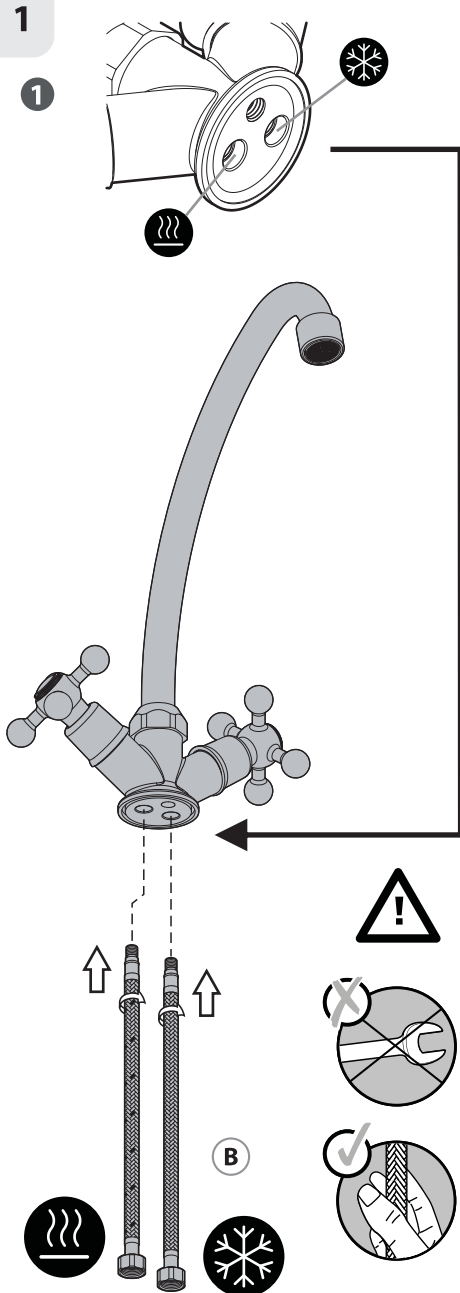

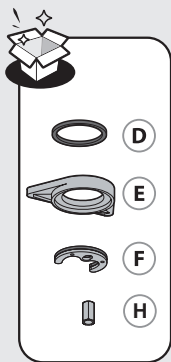

2

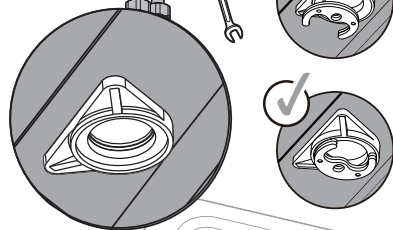
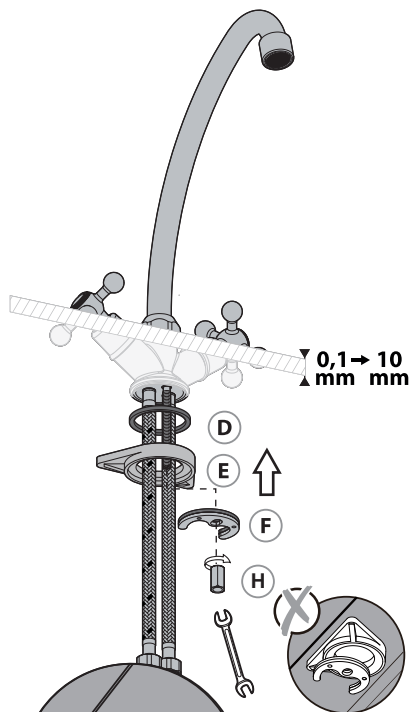
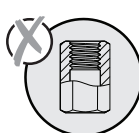
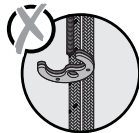
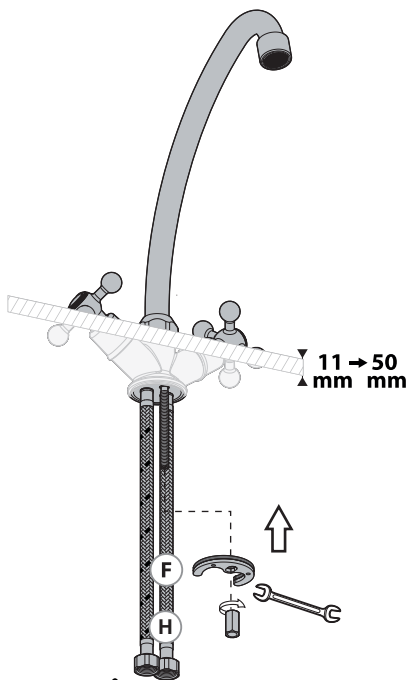
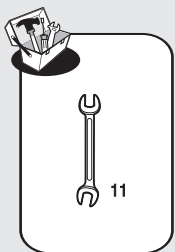
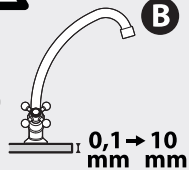
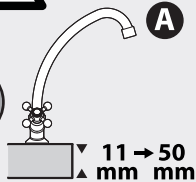

E

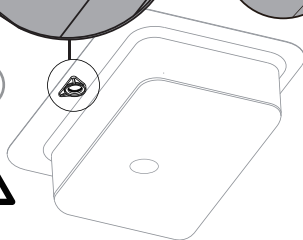

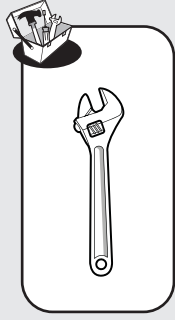

3

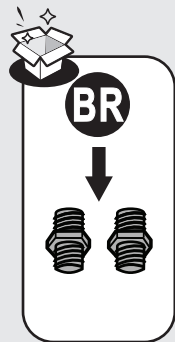
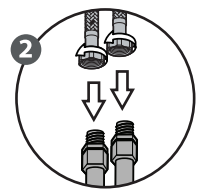
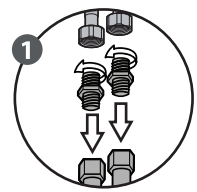
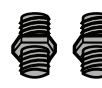
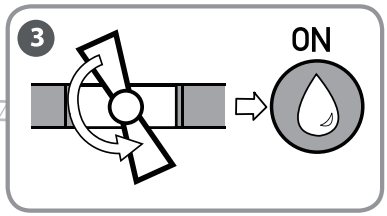
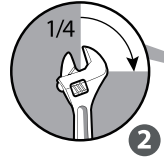
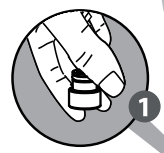
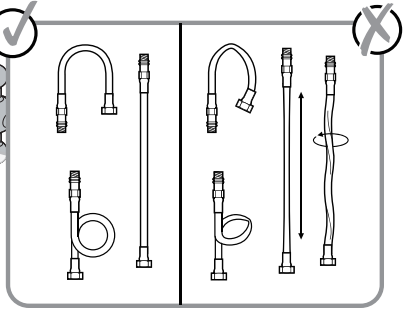
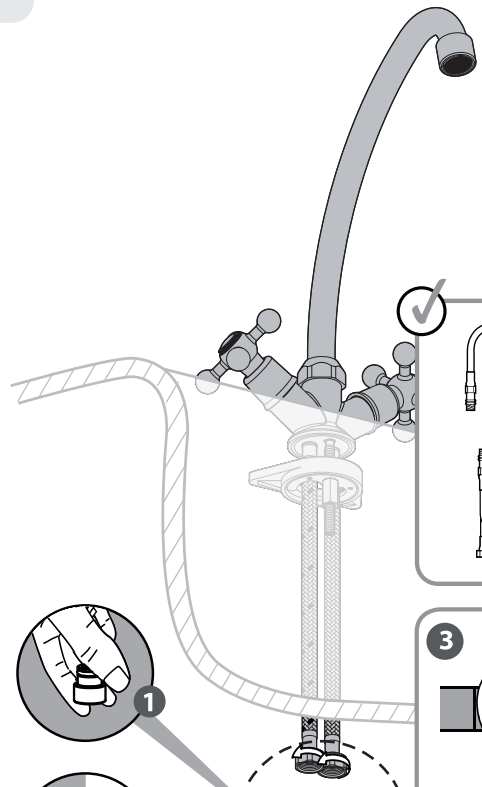



**FR:** Utilisation eau chaude-eau froide/ **ES:** Utilización agua caliente-agua fría/ **PT:** Utilização água quente-água fria/  
**IT:** Uso acqua calda-acqua fredda/ **EL:** Χρήση ζεστού-κρύου νερού/ **PL:** Użytkowanie zimnej wody-gorącej wody/  
**RU:** Використання гарячої води/ **KZ:** Суық және ыстық суды қолдану/ **UA:** води - холодної води/  
**RO:** Utilizare apă caldă-apă rece/ **BR:** Uso de água quente e fria/ **EN:** Using hot and cold water

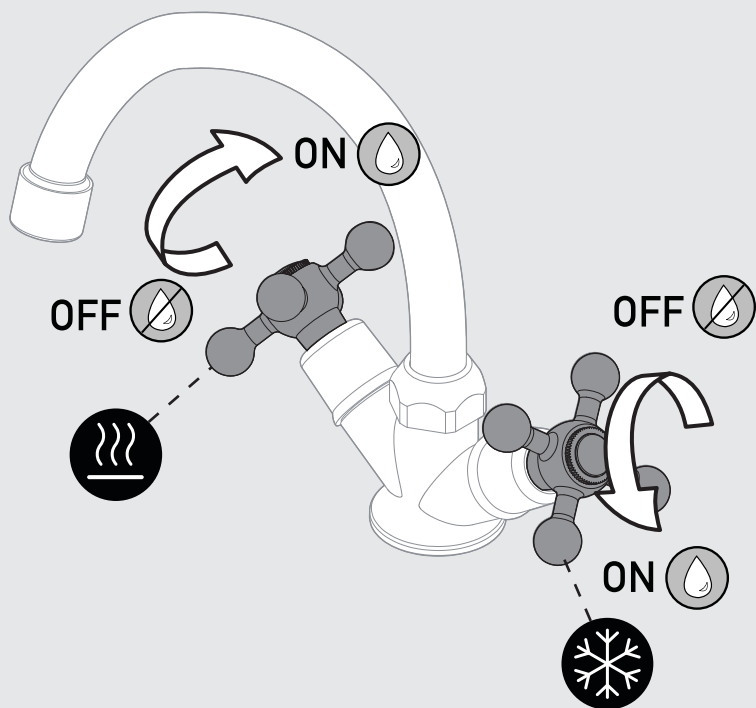
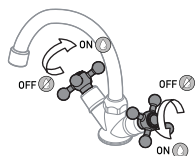





FR: Changement de cartouche/ ES: Cambio de cartucho/ IT: Cambio cartuccia/ PT: Mudança de cartucho/  
EL: Αλλαγή φιλτράριου/ PL: Wymiana wkładu / RU: Смена картриджа/ KZ: Картриджді ауыстыру/  
UA: Заміна картриджа/ RO: Schimbare cartuş/ BR: Substituição de cartucho/ EN: Replacing the cartridge

1

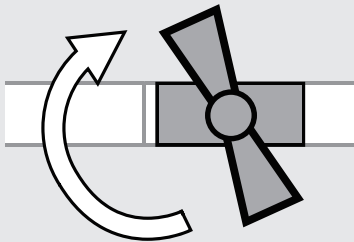

2

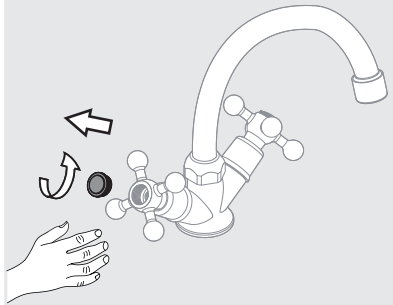

3

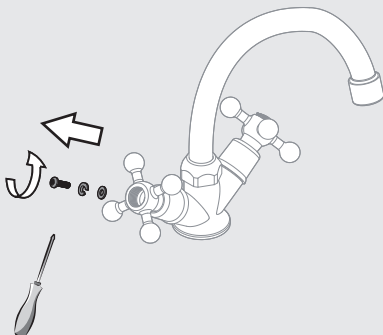

4

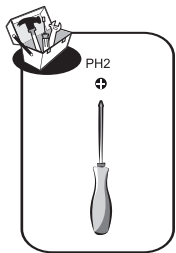
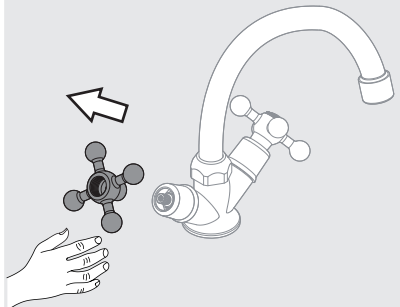



FR: Changement de cartouche/ ES: Cambio de cartucho/ IT: Cambio cartuccia/ PT: Mudança de cartucho/  
EL: Αλλαγή φιοσιγγίου/ PL: Wymiana wkładu / RU: Смена картриджа/ KZ: Картриджді ауыстыру/  
UA: Заміна картриджа/ RO: Schimbare cartuş/ BR: Substituição de cartucho/ EN: Replacing the cartridge

5

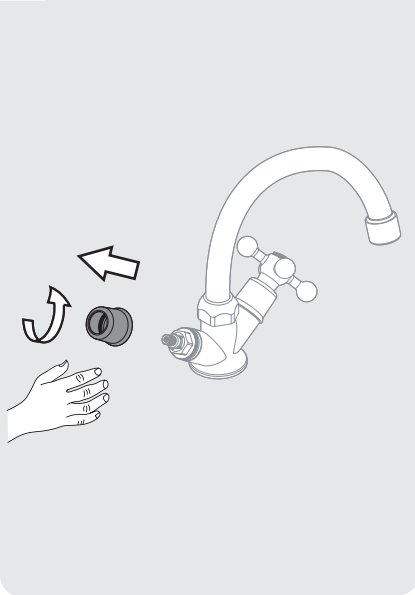

6



7

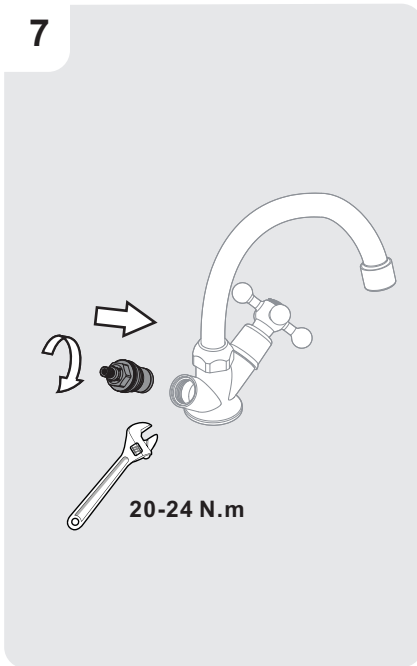

8

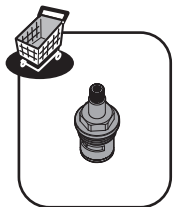
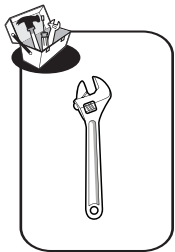
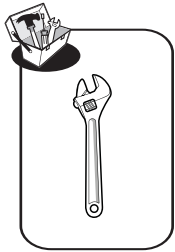

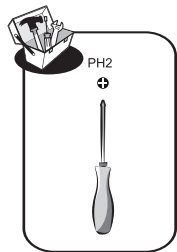

**FR:** Changement de cartouche/ **ES:** Cambio de cartucho/ **IT:** Cambio cartuccia/ **PT:** Mudança de cartucho/  
**EL:** Αλλαγή φαισγγίου/ **PL:** Wymiana wkładu / **RU:** Смена картриджа/ **KZ:** Картриджді ауыстыру/  
**UA:** Заміна картриджа/ **RO:** Schimbare cartuş/ **BR:** Substituição de cartucho/ **EN:** Replacing the cartridge

9

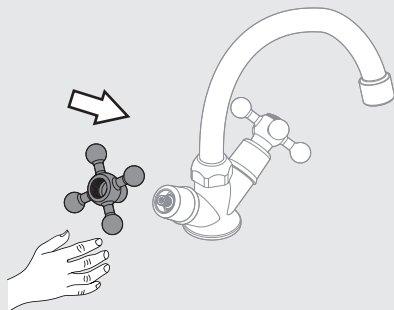

10

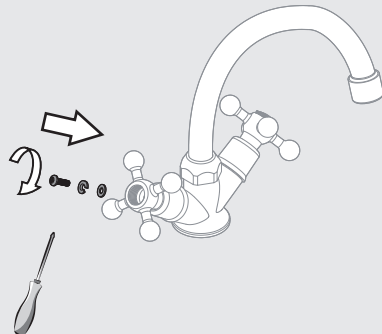

11

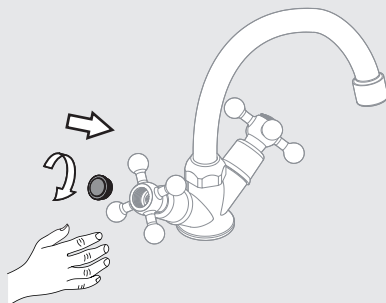

12

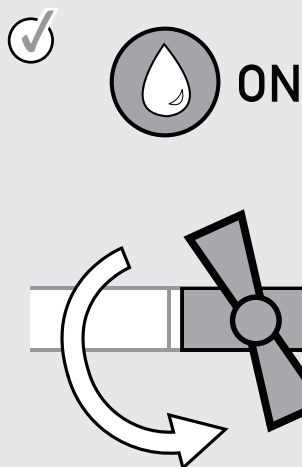



**FR:** Changement de mousseur/ **ES:** Cambio de aireador/ **PT:** Mudança de arejador/ **IT:** Cambio rompigitto/  
**EL:** Αλλαγή αεράτορα / **PL:** Wymiana perlatora / **RU:** Смена аэратора/ **KZ:** Ауақанықтырғышты ауыстыру/  
**UA:** Заміна аератора/ **RO:** Schimbare aerator/ **BR:** Substituição do aerador/ **EN:** Replacing the aerator

1

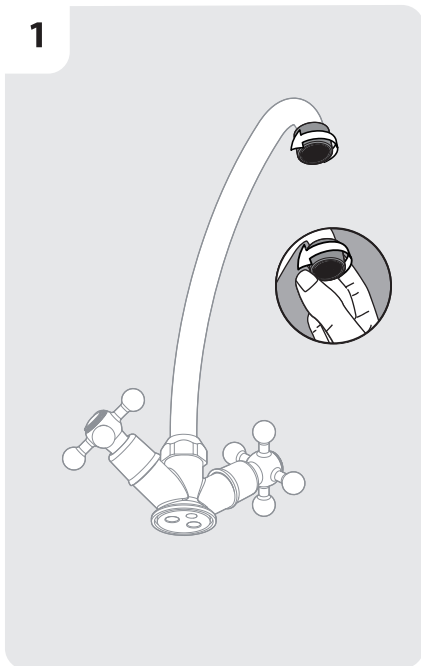

2

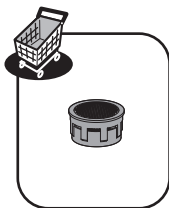
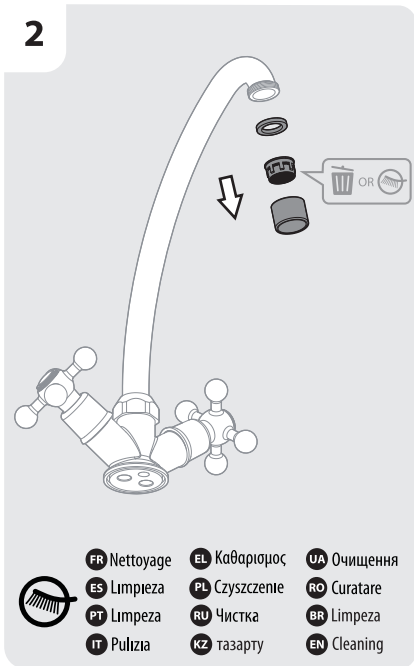

3

<b>FR</b> Vinaigre	<b>IT</b> Aceto	<b>RU</b> Уксус	<b>RO</b> Oțet
<b>ES</b> Vinagre	<b>EL</b> Ξύδι	<b>KZ</b> Сірке су	<b>BR</b> Vinagre
<b>PT</b> Vinagre	<b>PL</b> Ocet	<b>UA</b> Оцет	<b>EN</b> Vinegar

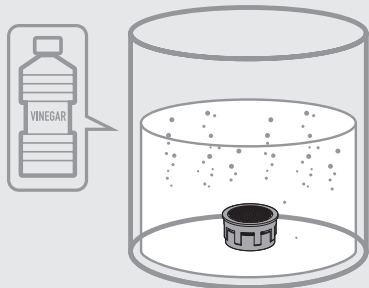

4

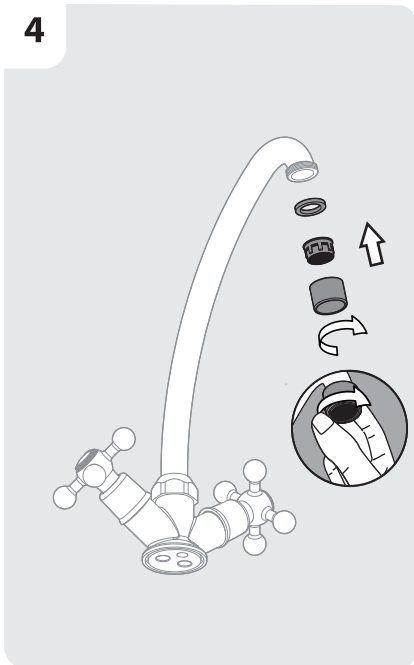

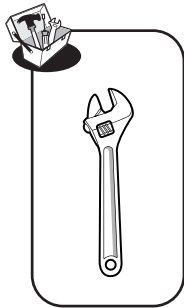

**FR:** Changement de flexibles/ **ES:** Cambio de flexibles/ **PT:** Mudança de flexíveis/ **IT:** Cambio flessibili/  
**EL:** Αλλαγή λάστιχων/ **PL:** Wymiana wężyków instalacyjnych / **RU:** Смена гибкого шланга для смесителя/  
**UA:** Заміна гнучкого шланга для змішувача/ **KZ:** Қоспалауышқа арналған иілгіш шлангты ауыстыру/  
**RO:** Schimbare furtune flexibile/ **BR:** Substituição das mangueiras/ **EN:** Replacing the hoses

1

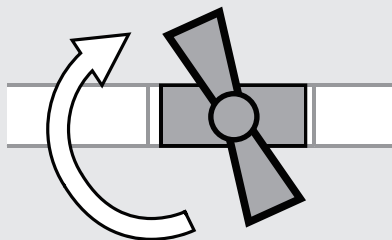

2

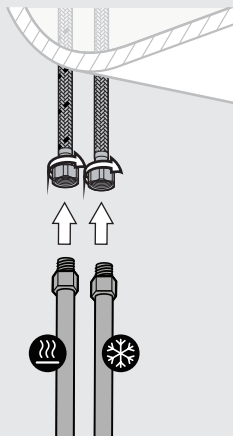

3

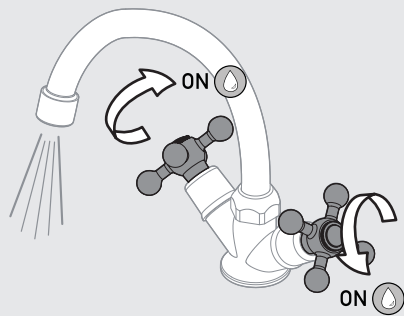

4

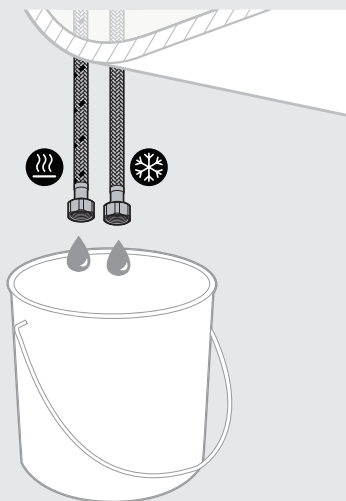



FR: Changement de flexibles/ ES: Cambio de flexibles / PT: Mudança de flexíveis/ IT: Cambio flessibili/  
EL: Αλλαγή λάστιχων/ PL: Wymiana wężyków instalacyjnych / RU: Смена гибкого шланга для смесителя/  
UA: Заміна гнучкого шланга для змішувача/ KZ: Қоспалауышқа арналған иілгіш шлангты ауыстыру/  
RO: Schimbare furtune flexibile/ BR: Substituição das mangueiras/ EN: Replacing the hoses

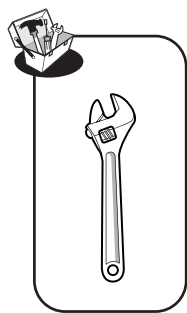

5

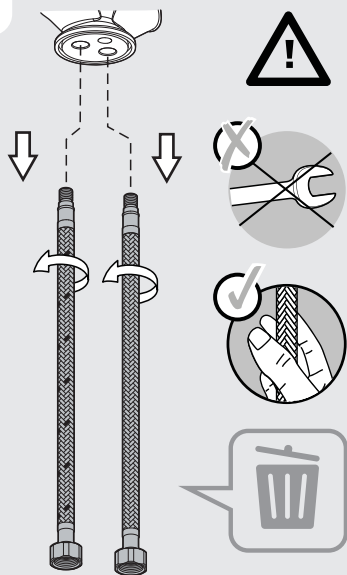

6

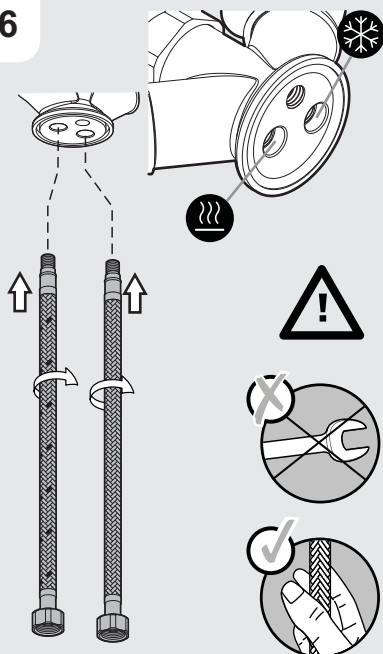

7

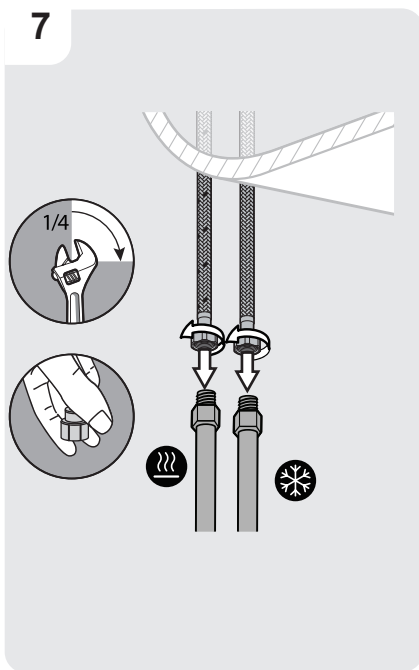

8

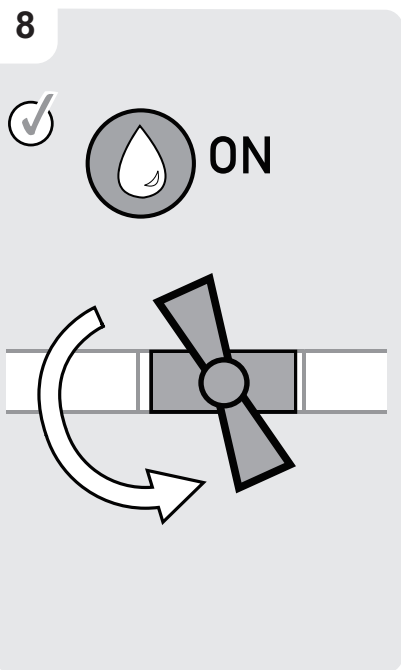



Eau claire / Agua limpia / Água limpa / Acqua pulita / Καθαρό νερό / Czysta woda / Чистая вода / Água limpa /  
Чиста вода / Ara curata / таза су / Clean water



Sans solvant / Sin disolvente / Sem solventes / Senza solventi / Χωρίς διαλυτικά / Bez rozpuszczalnika / Без растворителя /  
Sem solventes/ Без розчинника / Fara solvent / еріткішціз/ Solvent-free

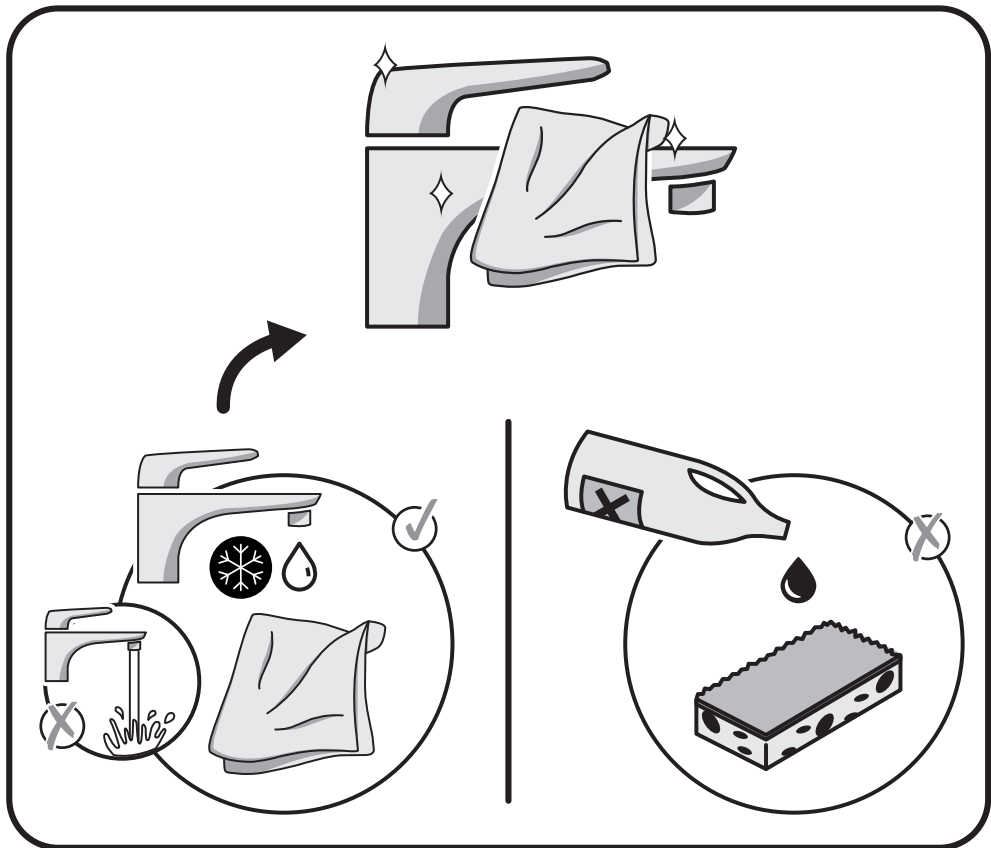

No.	Description	Code No.	QTY	Remark
1	Handle	SD98905L-00-04	2	3276000592303 / 3276000632351
		SD98905L-Y-04		3276000592310 / 3276000632375
2	Beautify Cover	SD98905L-01-03	2	3276000592303 / 3276000632351
		SD98905L-Y-03		3276000592310 / 3276000632375
3	Cartridge	19MC01	2	
4	Mixer Body	SD98905L-00-01	1	3276000592303 / 3276000632351
		SD98905L-Y-01		3276000592310 / 3276000632375
5	Spout	SD98905L-00-02	1	3276000592303 / 3276000632351
		SD98905L-Y-02		3276000592310 / 3276000632375
6	Aerator	40,2104.000	1	
7	Aerator shell	SD3101-2201A-03	1	3276000592303 / 3276000632351
		SD3101-2201A-03-Y		3276000592310 / 3276000632375
8	O-ring	Ø40X3	1	
9	Triangle base	SD60045C-2-13	1	
10	Fixing set	SD90015-00-06A	1	
11	Inlet hose	TAQ-PEX-DN6-ACB H3/8-M8X1 L12-450	2	3276000592303 / 3276000592310
		TAQ-PEX-DN6-ACB H1/2-M8X1 L12-450		3276000632351 / 3276000632375
12	Joint	SD606-012S	2	

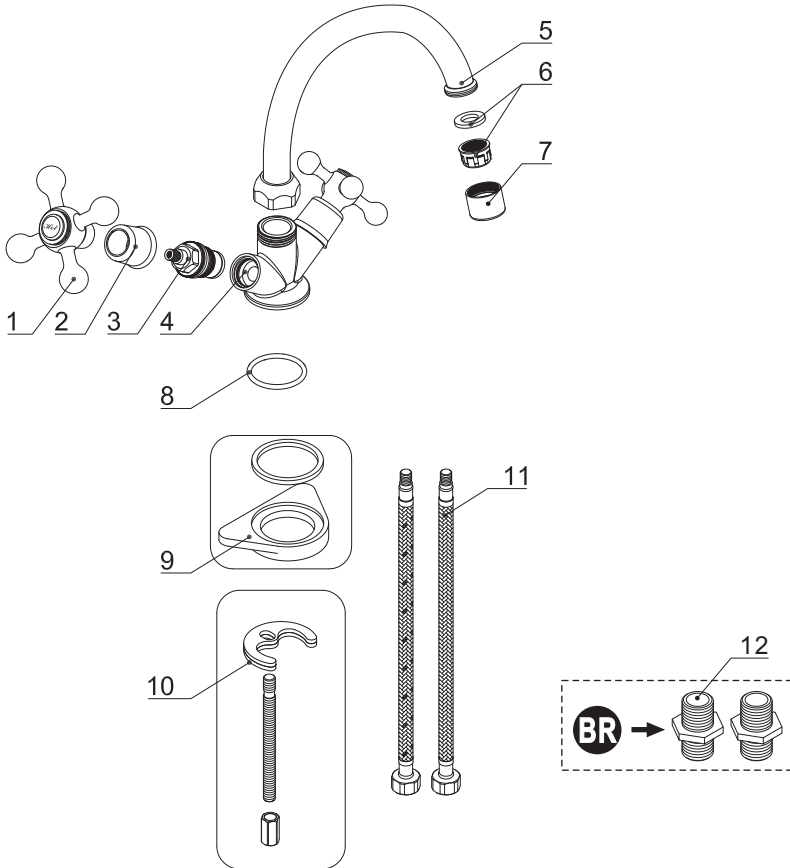





Certificado de conformidad sanitaria.  
Atestado de conformidade sanitária.  
certificato di conformità sanitaria.  
Βεβαίωση υγειονομικής συμμόρφωσης.  
Certyfikat zgodności sanitarnej.  
Декларация о соответствии санитарным нормам  
Санитарлық талаптарға сәйкестік декларациясы  
Декларація про відповідність санітарним нормам  
Atestat de conformitate sanitară  
Certificado de conformidade sanitária.  
Declaration of sanitary conformity.  
Attestation de conformité sanitaire

\* Garantie 10 ans / 10 años de garantía / Garantia de 10 años / Garanzia 10 Anni / Εγγύηση 10 ετών / Gwarancja 10-letnia / Гарантия 10 года / Кепілдік 10 жыл / Гарантія 10 років / Garanție 10 ani / 10 anos de garantia / 10-year guarantee

Made in P.R.C. 2018

ADEO Services - 135 Rue Sadi Carnot - CS 00001  
59790 RONCHIN - France



ТОВ «Леруа Мерлен Україна»,  
вул. Полярна 17а, м. Київ 04201, Україна

