

DEXTER POWER

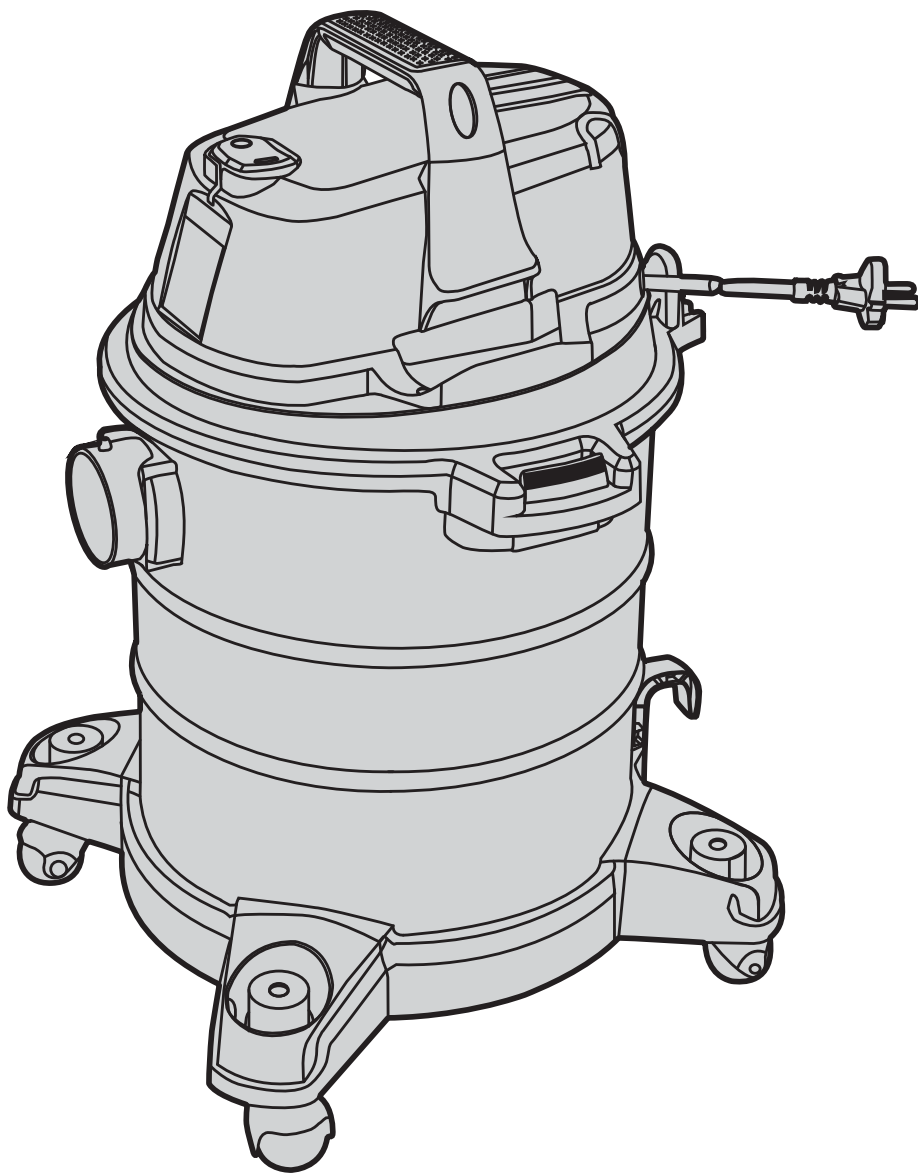

WATER AND DUST VACUUM CLEANER VOD1420SF



- FR Notice de Montage - Utilisation - Entretien
- ES Instrucciones de Montaje, Utilización y Mantenimiento
- PT Instruções de Montagem, Utilização e Manutenção
- IT Istruzioni per il Montaggio, l'Uso e la Manutenzione
- EL Εγχειρίδιο συναρμολόγησης, χρήσης και συντήρησης
- PL Instrukcja Montażu, Użytkowania i Konserwacji
- KZ Құрастыру - Пайдалану - Техникалық қызмет көрсету нұсқаулығы
- RU Руководство По Сборке и Эксплуатации
- UK Керівництво По Збірці і Експлуатації
- RO Manual asamblare, utilizare și întreținere
- EN Assembly - Use - Maintenance Manual

EAN CODE : 3276000237679



Traduction de la version originale du mode d'emploi / Traducción de las Instrucciones originales / Tradução das Instruções Originais / Traduzione delle istruzioni originali / Μετάφραση των πρωτότυπων οδηγιών /
Tłumaczenie instrukcji oryginalnej / Түпнұсқа нұсқаулардың аудармасы / Перевод оригинала инструкции / Переклад оригінальної інструкції / Traducerea instrucțiunilor originale /
Original Instructions

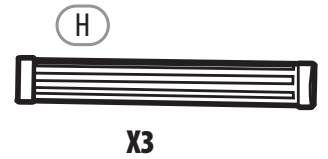
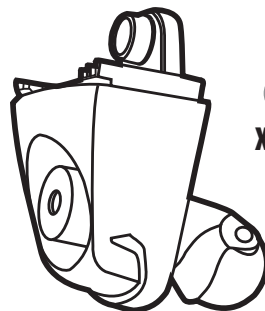
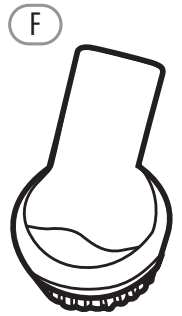
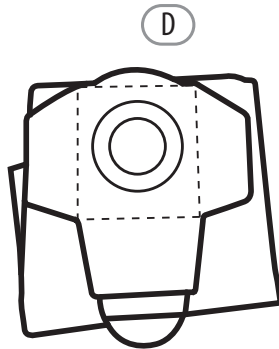
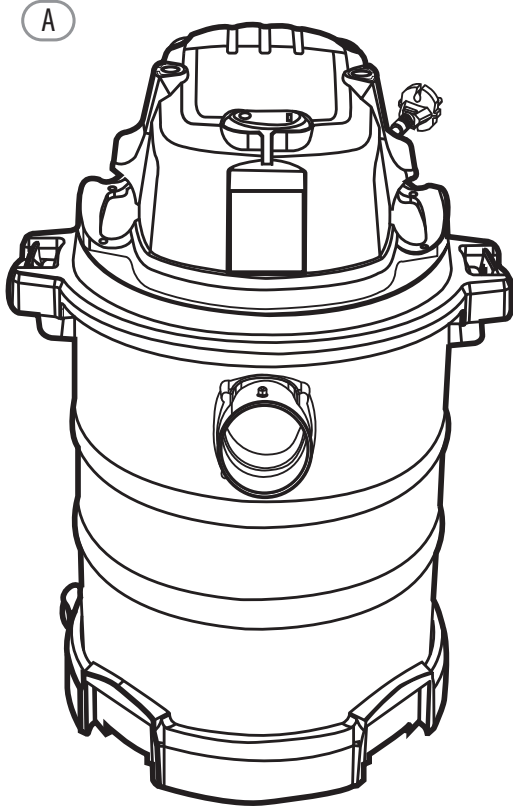
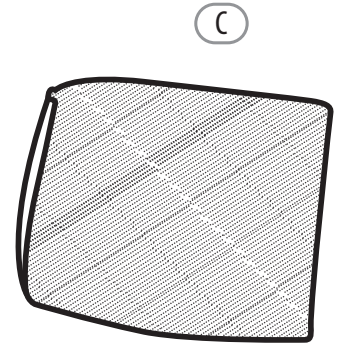
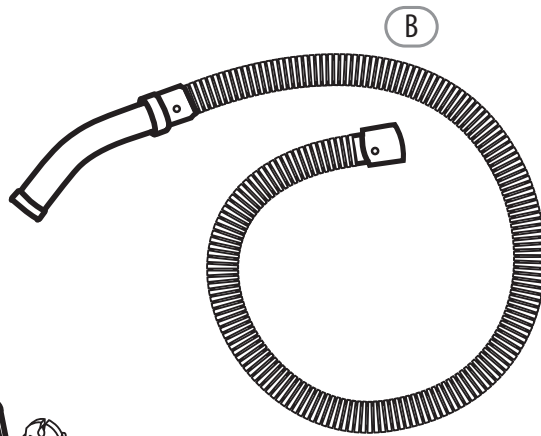
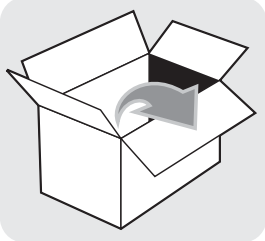

OPTIONS / OPCIONES / OPÇÕES / OPZIONI / ΕΠΙΛΟΓΕΣ / OPĆJE /
ОПЦИЈАЛАР/ОПЦИИ / ОПЦІЇ / OPȚIUNI / OPTIONS

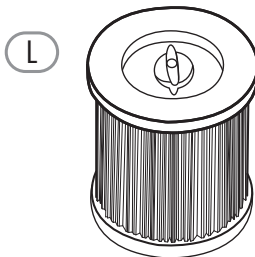

Not HEPA

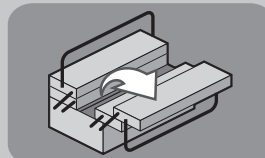
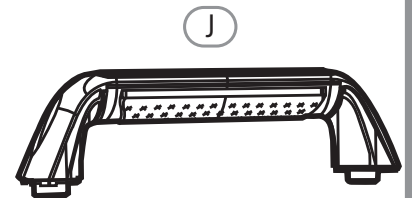
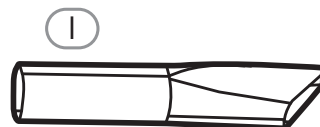

+ PZ





Attention danger / Atención: Peligro / Atencão perigo / Attenzione pericolo / Προσοχή κίνδυνος /
Uwaga niebezpieczeństwo / Назар аударыңыз! Қауіпті!/Внимание! Опасно! / Увага! Небезпечно! / Atenție, pericol /
Caution danger



Observez / Atención / Aviso / Osservare / Προσέξτε / Przestrzegać / Техникалық қауіпсіздік ережелерін сақтаңыз /
Соблюдайте правила техники безопасности / Дотримуйтеся правил техніки безпеки / Respectați / Observe



Raccordé / Conectado / Ligado / Connesso / Με σύνδεση / Podłączone / Жалғанған/Подключено /
Під'єднано / Conectat / Connected



Hors tension / Apagado / Desligado da alimentação / Fuori tensione / Εκτός τάσης / Odłączenie zasilania /
Өшіру/Не под напряжением / Не під напругою / Scoatere de sub tensiune / Power off



Mise sous tension / Puesta en tensión / Ligação da alimentação / Messo sotto tensione /
Σύνδεση με το ηλεκτρικό δίκτυο / Włączenie zasilania / Қосу/Включение под напряжение /
Під'єднання під напругу / Punere sub tensiune / Power up



Nettoyage / Limpieza / Limpeza / Pulizia / Καθαρισμός / Czyszczenie / Тазалау/Чистка / Очищення /
Curățare / Cleaning



Correct / Correcto / Corretto / Corretto / Σωστό / Dobrze / Дұрыс/Правильный /
Правильно / Corect / Correct



Mentions légales & consignes de sécurité / Instrucciones legales y de seguridad / Avisos legais e instruções de segurança /
Istruzioni legali e di sicurezza / νομικό σημείωμα και οδηγίες ασφαλείας / uwagi prawne i instrukcja bezpieczeństwa /
Құқықтық және қауіпсіздік туралы нұсқаулар/руководство по технике безопасности и правовым нормам /
керівництво з техніки безпеки і правовим нормам /
manual privind siguranța și aspectele juridice / Legal & safety instructions



Aspirateur / Aspirar / Aspiração / Aspiratore / Αναρρόφηση / Odkurzacz / Сору/Пылесос /
Прибирання пилососом / Aspirare / Vacuum



Souffleur / Soplar / Sopro / Soffiatore / Φύσημα / Nadmuch / Үрлеп шығару/Сдувание /
Продувати / Suflare / Blow



Lire les instructions de fonctionnement / Lea el manual de instrucciones detenidamente / Leia as instruções de funcionamento /
Leggere attentamente le istruzioni di sicurezza / Διαβάστε προσεκτικά τις οδηγίες λειτουργίας / Przeczytaj uważnie instrukcję
użytkowania / Пайдалану жөніндегі нұсқауларды мұқият оқып шығыңыз/Внимательно прочтите инструкцию по
эксплуатации. / Уважно прочитайте інструкцію з експлуатації. /Citiți cu atenție instrucțiunile de utilizare / Read the
operating instructions carefully



Porter une protection pour les yeux / Utilice protección ocular / Use proteção ocular / Indossare protezioni per gli occhi /
Φοράτε προστασία για τα μάτια / Noś okulary ochronne / Көз қорғанысын киіңіз/
Используйте средства защиты органов зрения / Надягайте захисні окуляри / Purtați echipament de protecție oculară /
Wear eye protection



Porter une protection respiratoire / Utilice protección respiratoria / Use proteção respiratória / Indossare protezioni respiratorie /
Φοράτε προστασία για την αναπνοή / Noś środki ochrony dróg oddechowych / Тыныс жолдарының қорғанысын
киіңіз/Используйте средства защиты органов дыхания / Надягайте протипилову маску / Purtați echipament de protecție
respiratorie / Wear breathing protection



Porter des gants de protection / Utilice guantes protectores / Use luvas de proteção / Indossare guanti protettivi /
Φοράτε προστατευτικά γάντια / Noś rękawice ochronne / Қорғаныш қолғап киіп жүріңіз/
Используйте защитные перчатки / Надягайте захисні рукавиці / Purtați mănuși de protecție / Wear protective gloves

**Notes / Observaciones / Notas / Note /
Σημειώσεις / Notatki / Ескертпелер/
Примечания / Примітки / Note /
Notes**

A

FR Préparation

ES Preparación

PT Preparação

IT Preparazione

EL Προετοιμασία

PL Przygotowanie

KZ Дайындық

UK Підготування

RO Pregătire

EN Preparation

RU Подготовка

1

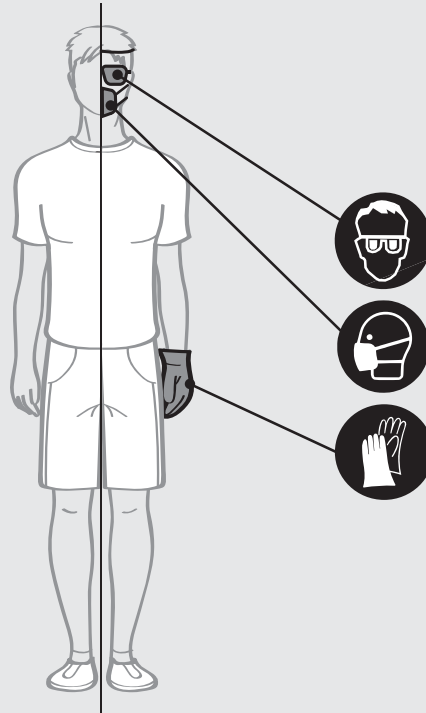

2

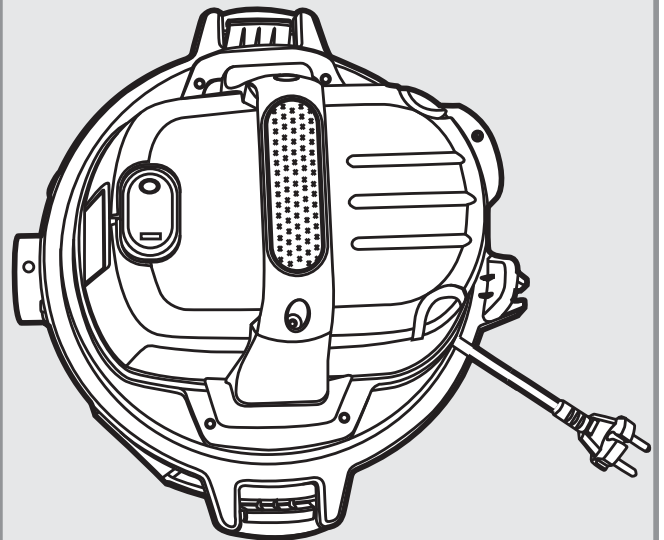
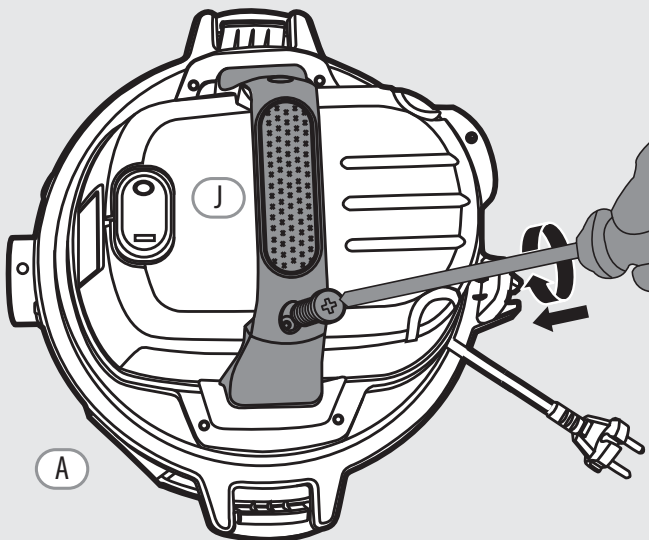

FR Préparation

ES Preparación

PT Preparação

IT Preparazione

EL Προετοιμασία

PL Przygotowanie

KZ Дайындық

UK Підготування

RO Pregătire

EN Preparation

RU Подготовка

A



3

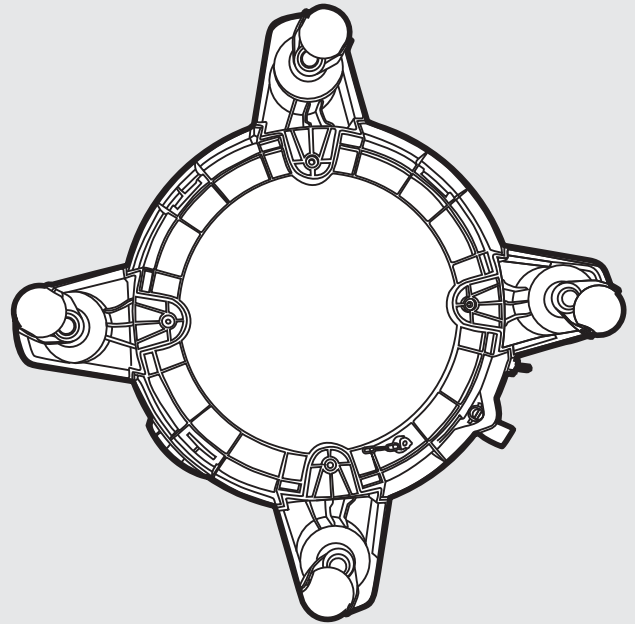
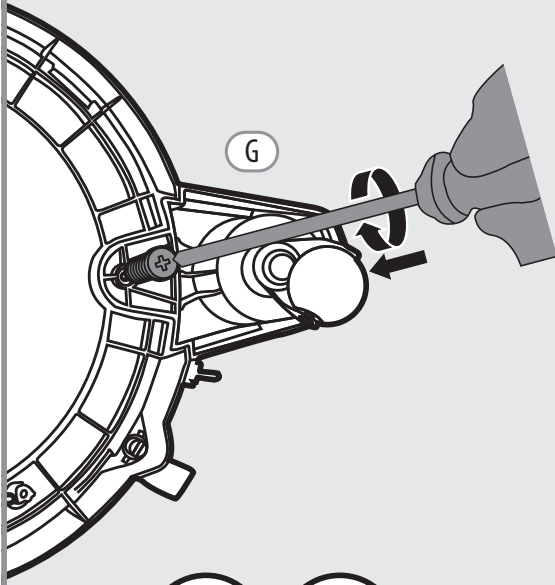

4

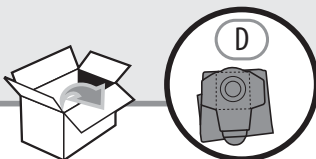
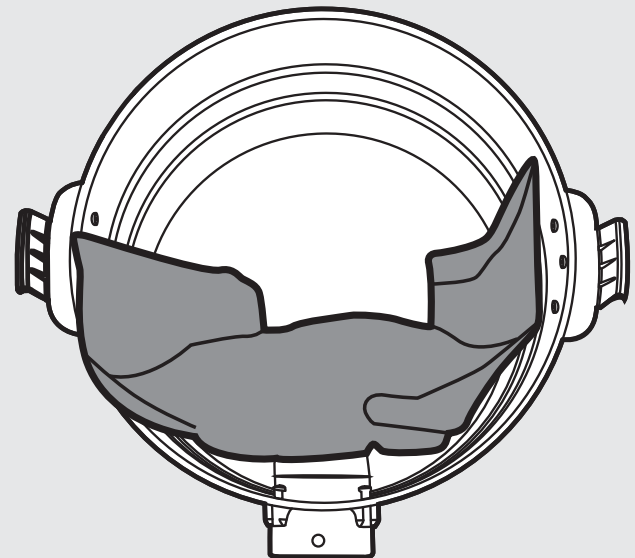
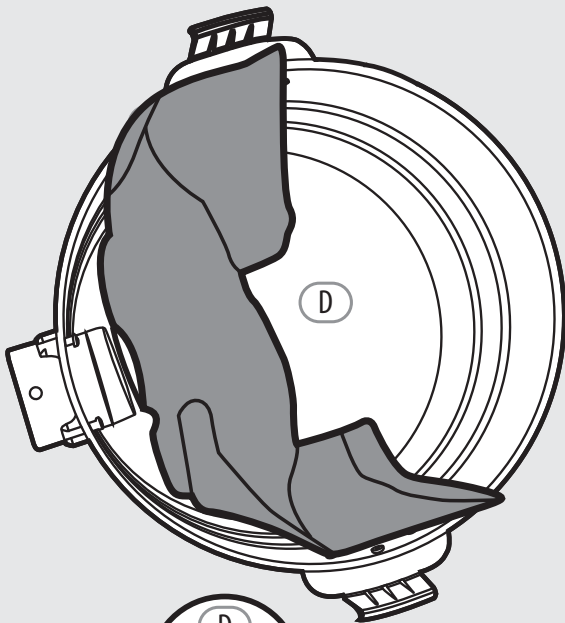

A

FR Préparation

ES Preparación

PT Preparação

IT Preparazione

EL Προετοιμασία

PL Przygotowanie

KZ Дайындық

UK Підготування

RO Pregătire

EN Preparation

RU Подготовка



5

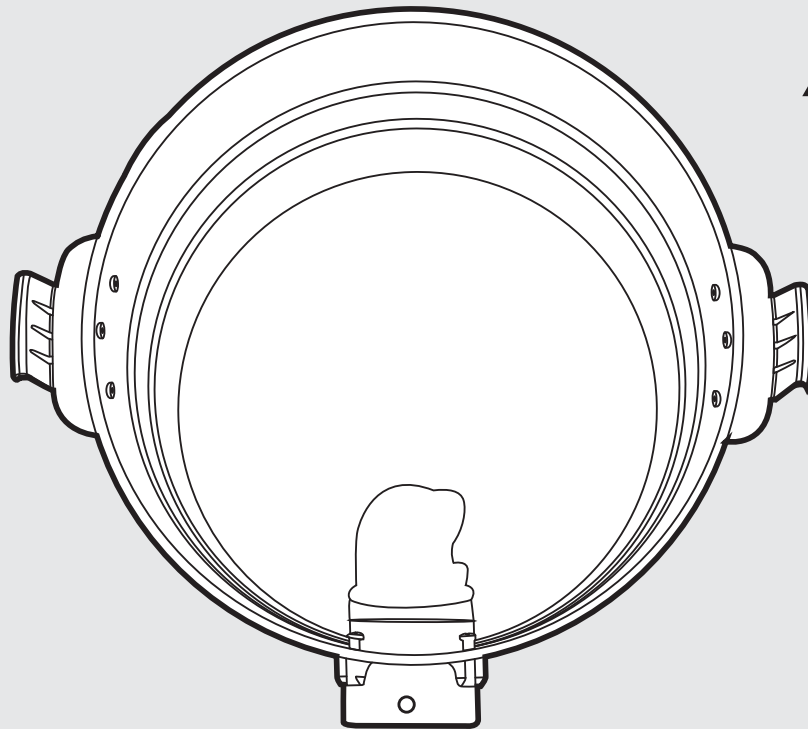

6

OPTIONS / OPCIONES / OPÇÕES / OPZIONI / ΕΠΙΛΟΓΕΣ / OPCJE / ОПЦИЯЛАР / ОПЦИИ / ОПЦІЇ / OPȚIUNI /
 OPTIONS

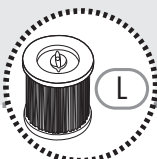
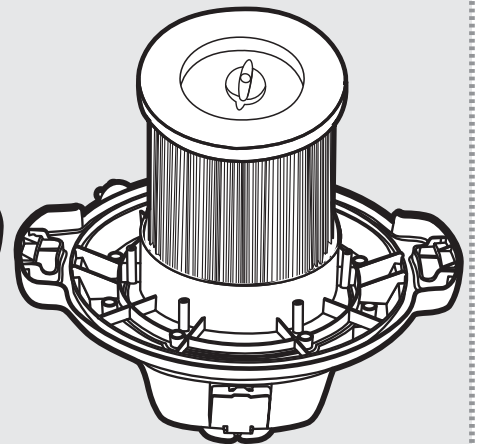
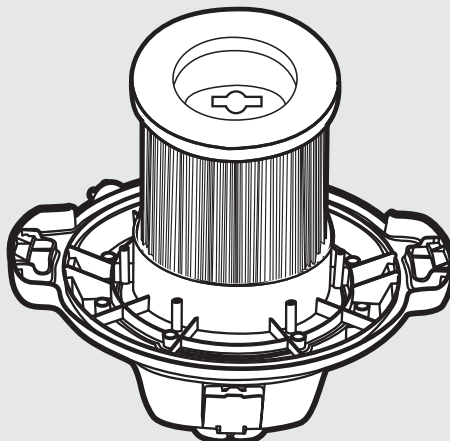
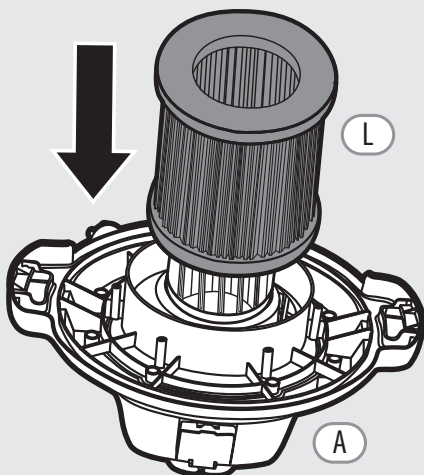

FR Préparation

ES Preparación

PT Preparação

IT Preparazione

EL Προετοιμασία

PL Przygotowanie

KZ Дайындық

UK Підготування

RO Pregătire

EN Preparation

RU Подготовка

A

7

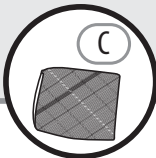
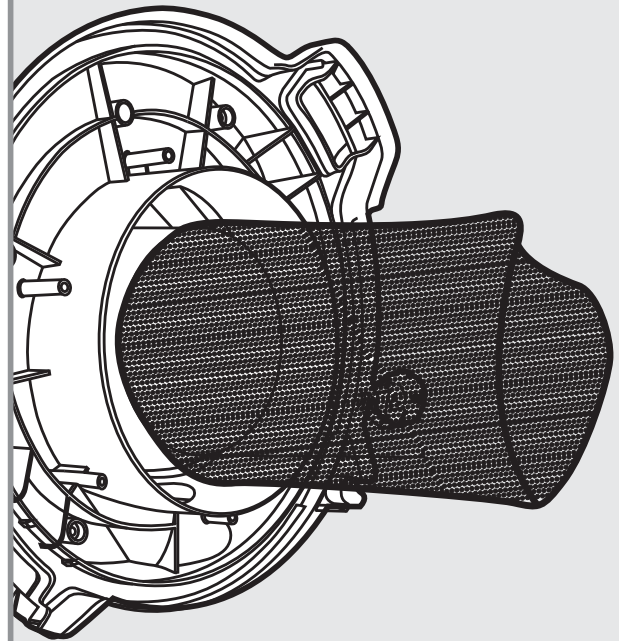
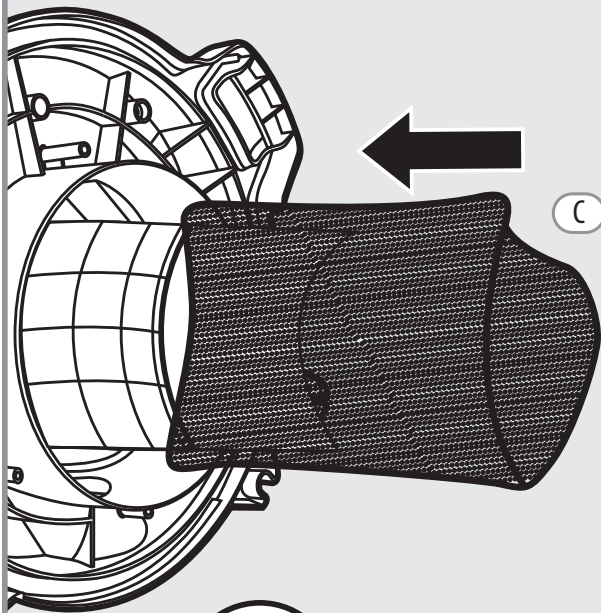

8

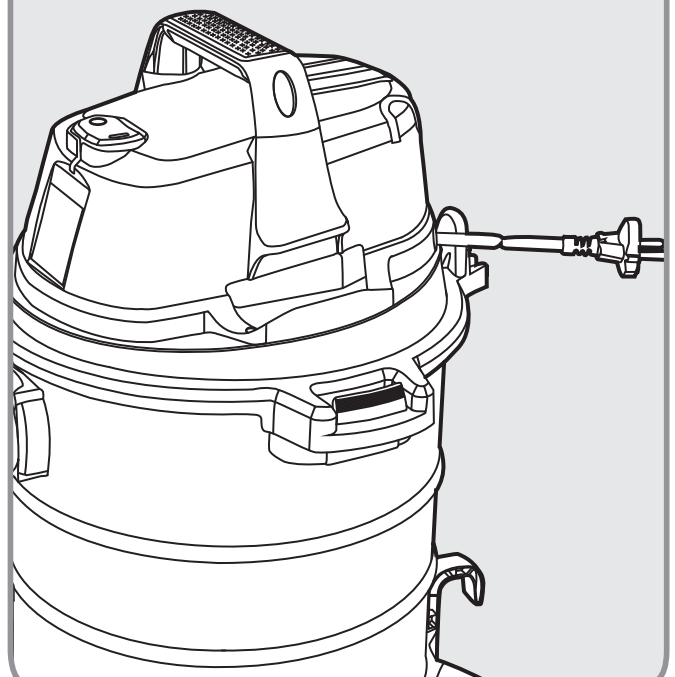
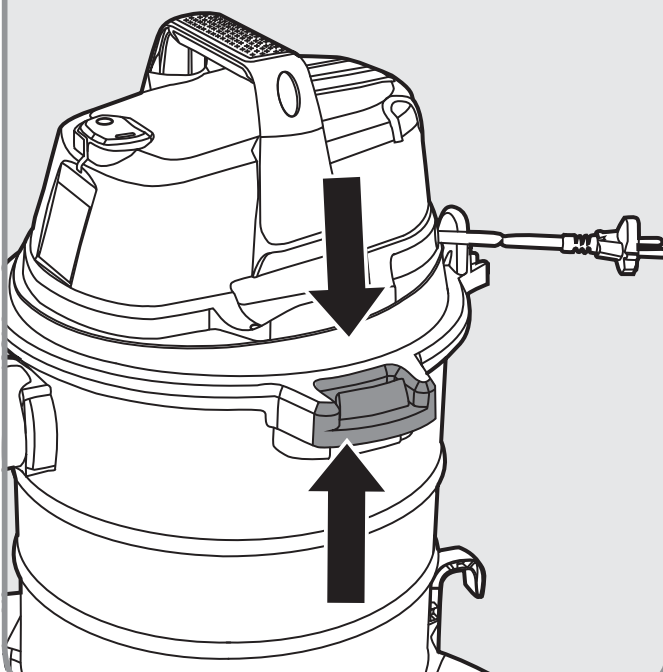

A

FR Préparation

ES Preparación

PT Preparação

IT Preparazione

EL Προετοιμασία

PL Przygotowanie

KZ Дайындық

UK Підготування

RO Pregătire

EN Preparation

RU Подготовка

9

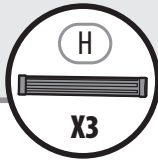
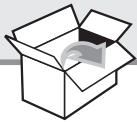
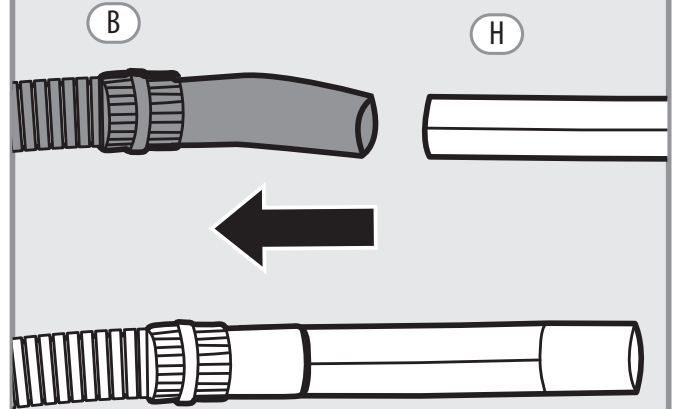
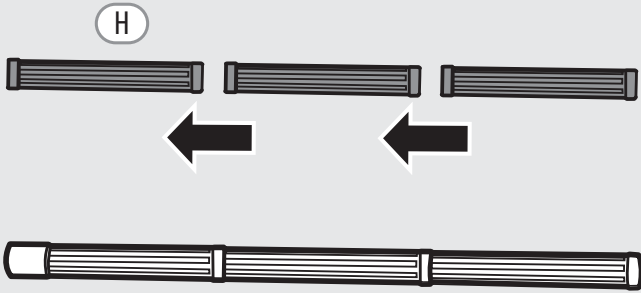

10

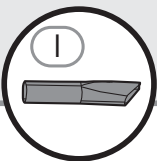
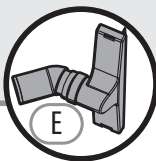
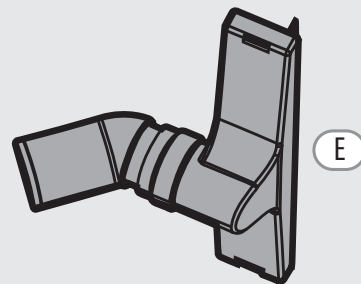
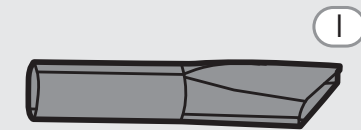
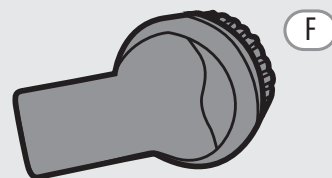
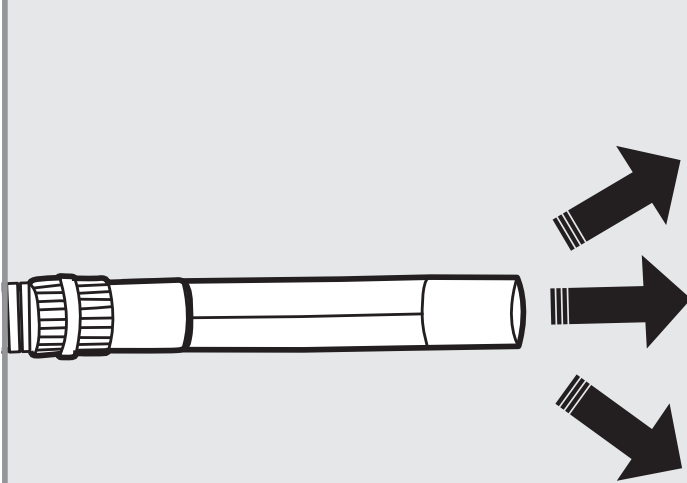

11

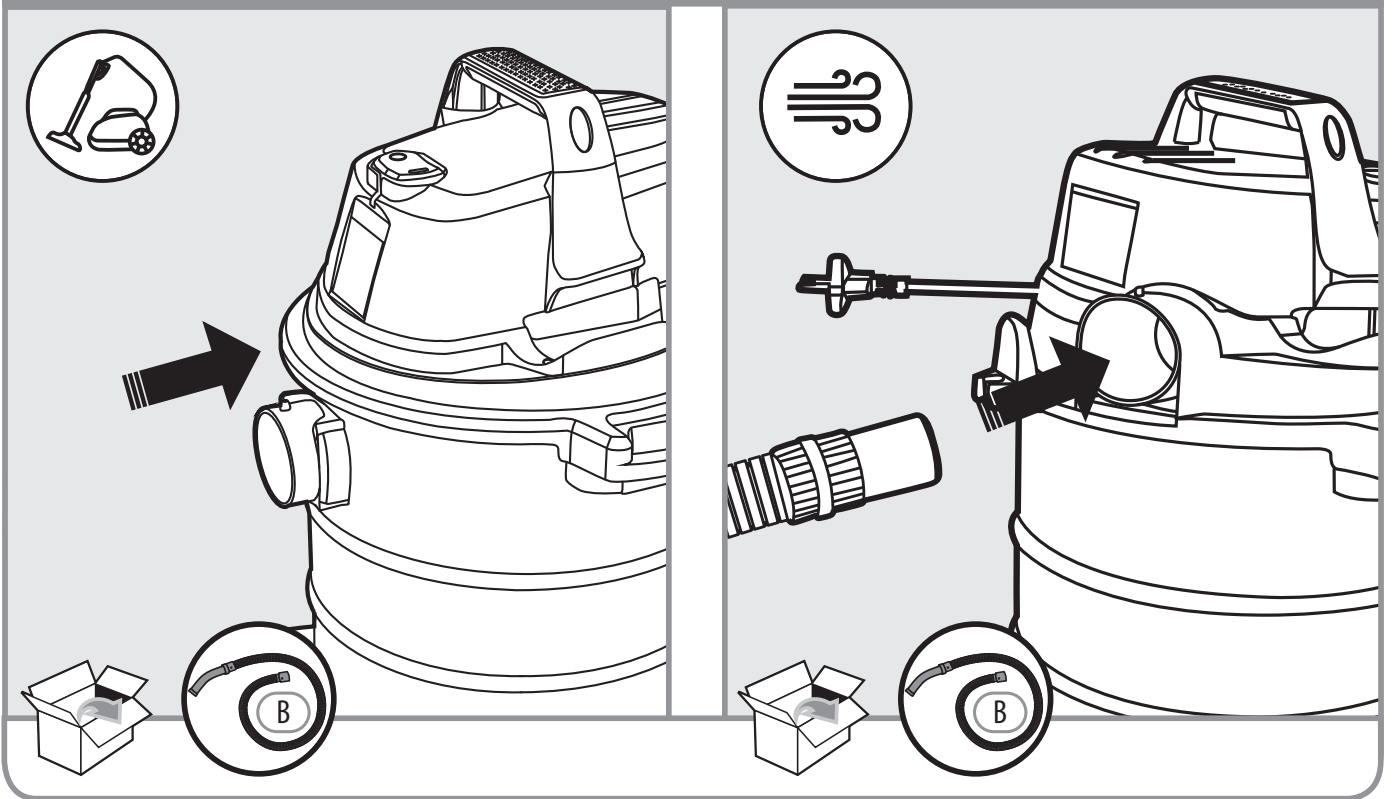

12

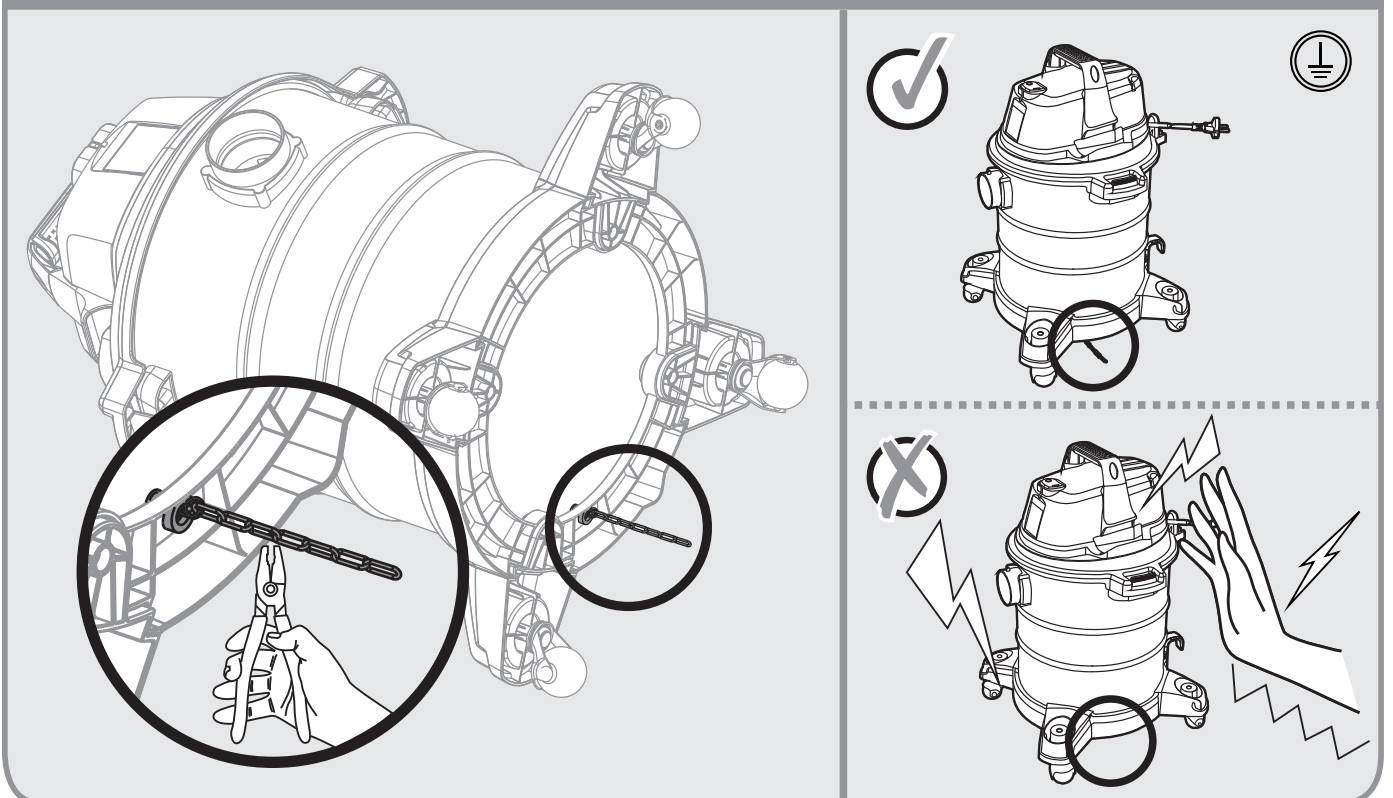

B

FR Utilisation

ES Utilización

PT Utilização

IT Uso

EL Χρήση

PL Użytkowanie

KZ Пайдалану

UK Використання

RO Utilizare

EN Use

RU Использование



1

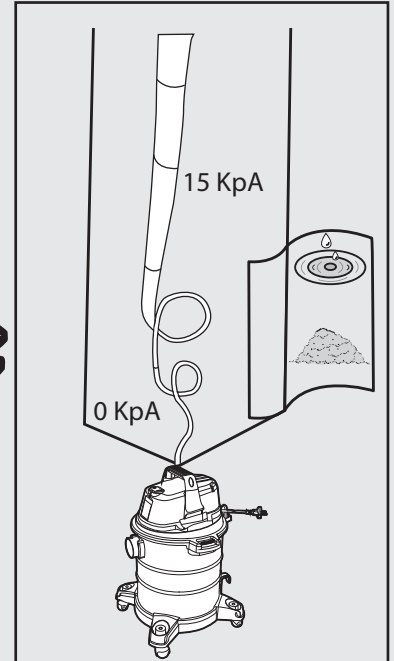
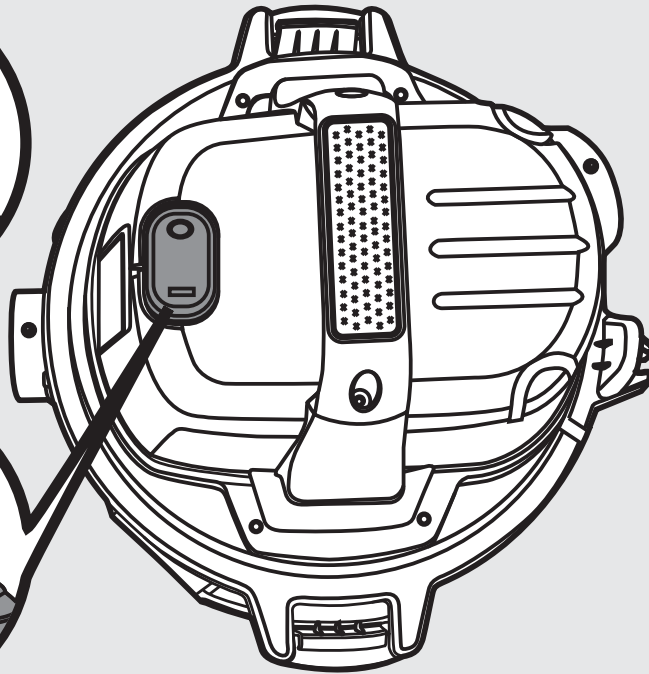
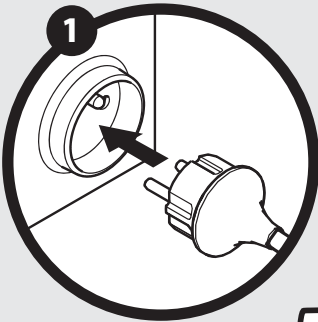

2

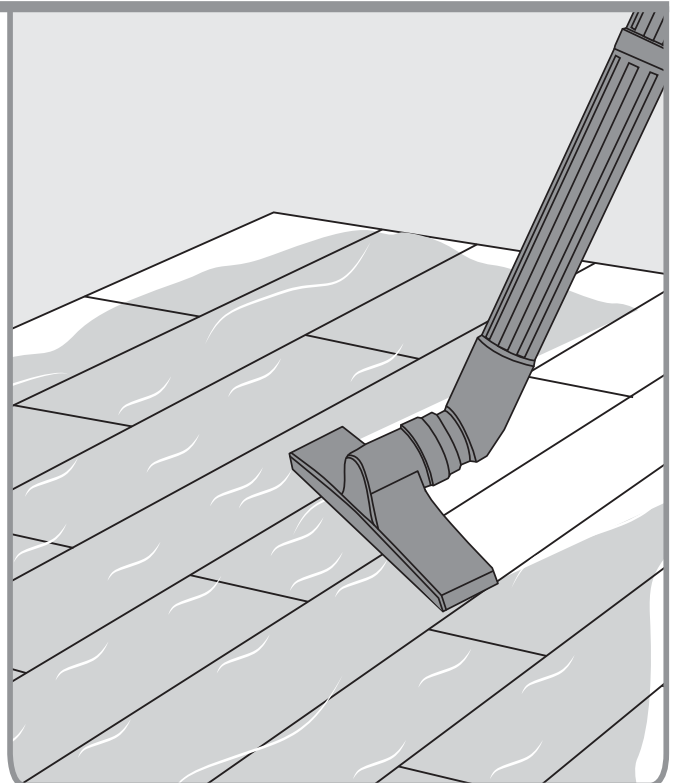
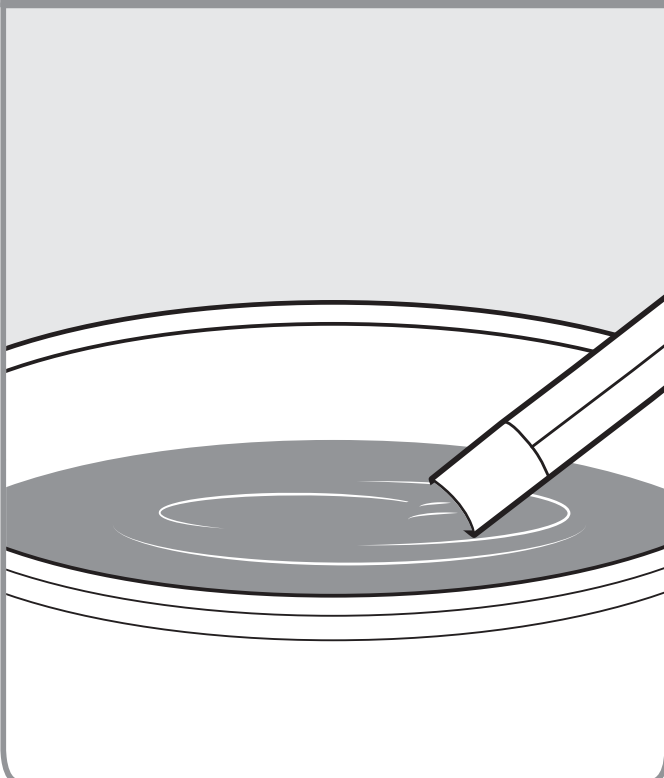

FR Utilisation

ES Utilización

PT Utilização

IT Uso

EL Χρήση

PL Użytkowanie

KZ Пайдалану

UK Використання

RO Utilizare

EN Use

RU Использование

B

3

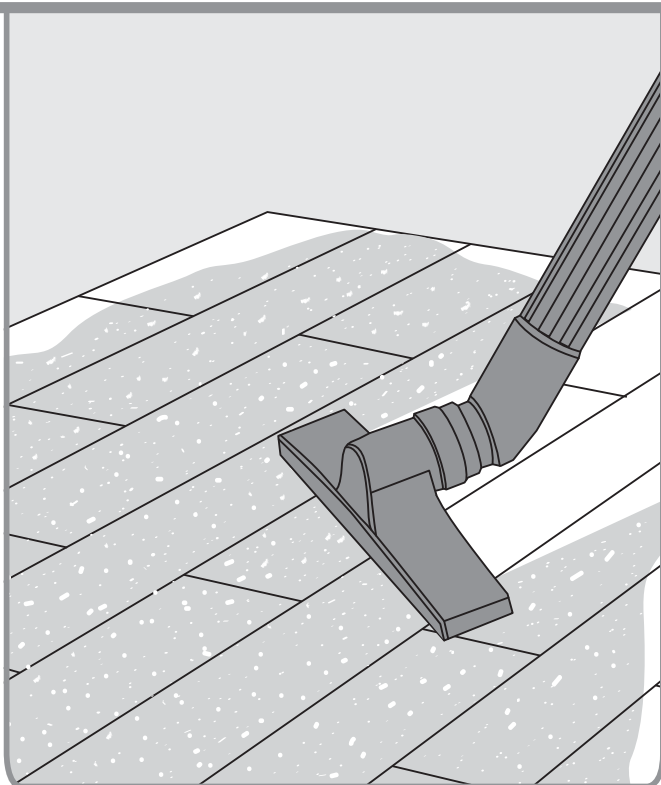
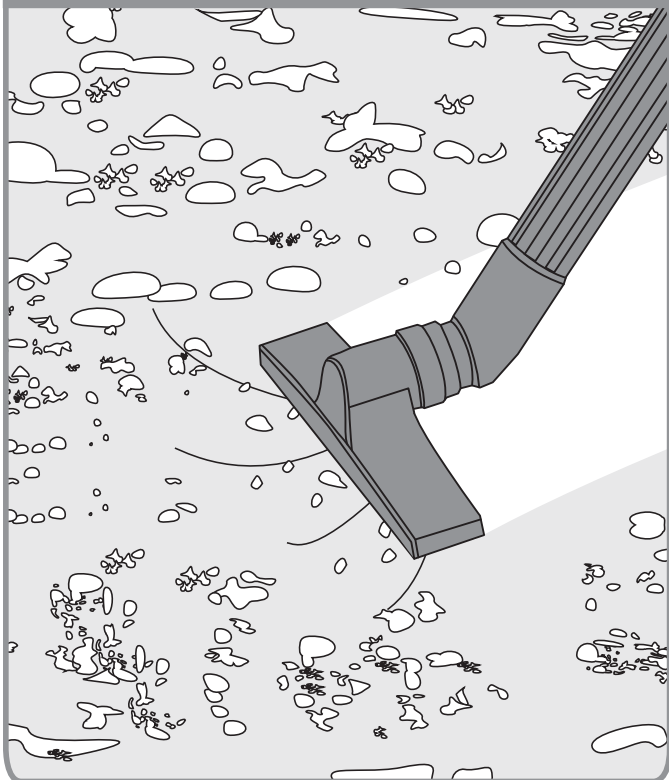

4

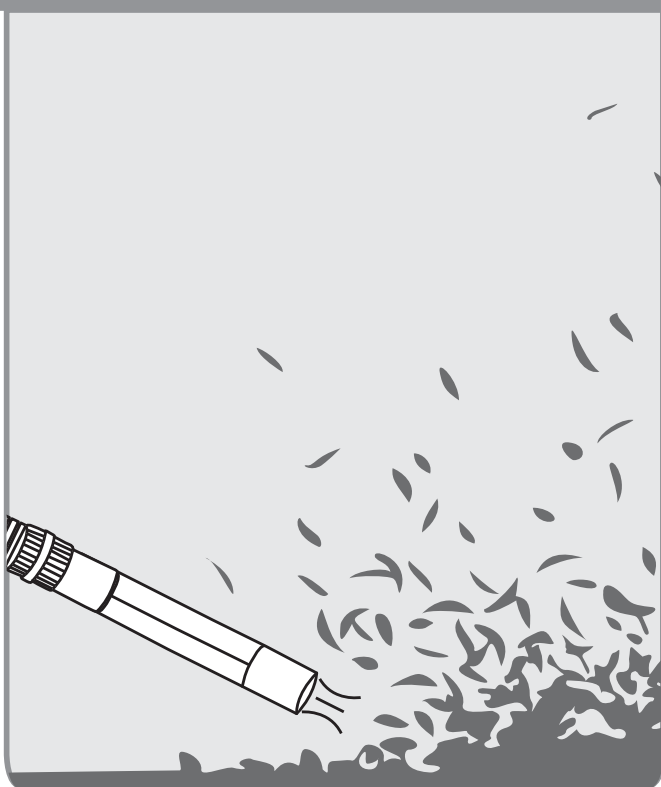
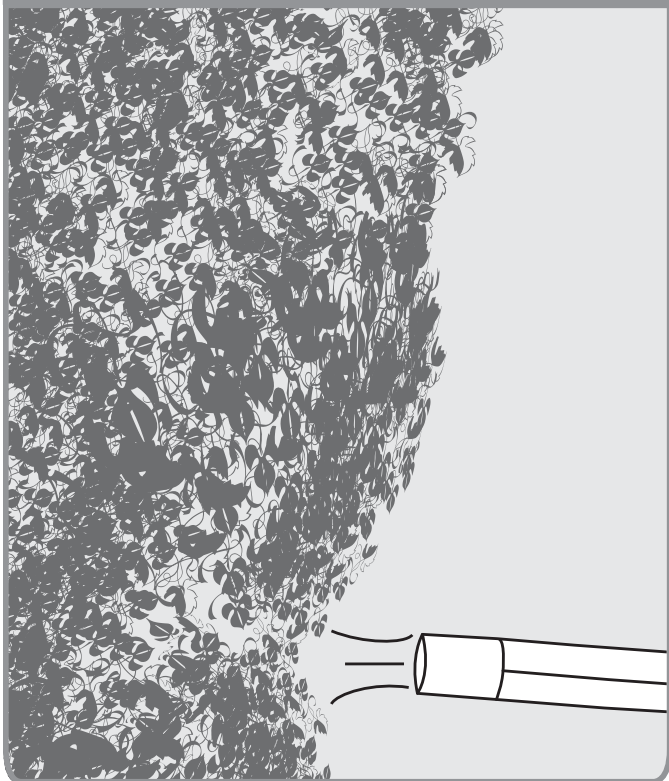

C

FR Entretien

ES Mantenimiento

PT Serviço

IT Manutenzione

EL Συντήρηση

PL Konserwacja

KZ Техникалық қызмет көрсету

UK Догляд

RO Întreținere

EN Maintenance

RU Уход



1

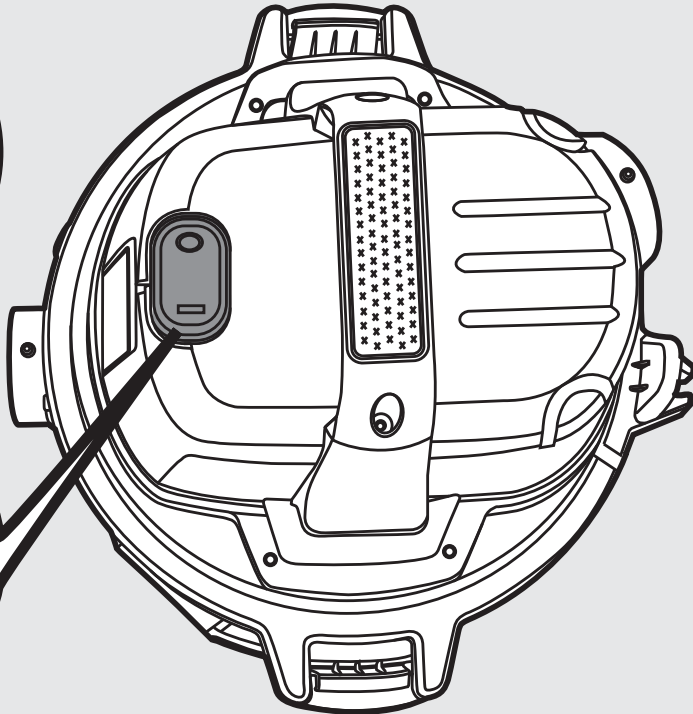
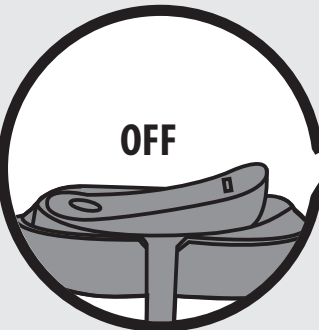

2



OPTIONS / OPCIONES / OPÇÕES / OPZIONI / ΕΠΙΛΟΓΕΣ / OPCJE / ОПЦІЯЛАР/ОПЦИИ / ОПЦІЇ / OPTIUNI / OPTIONS

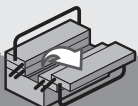
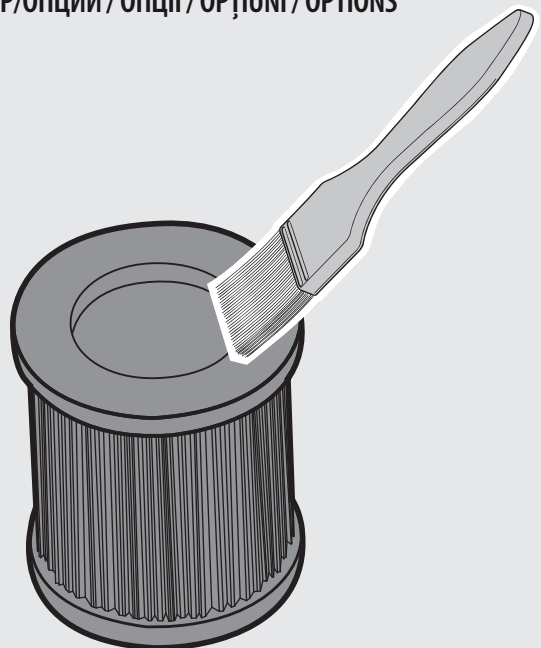
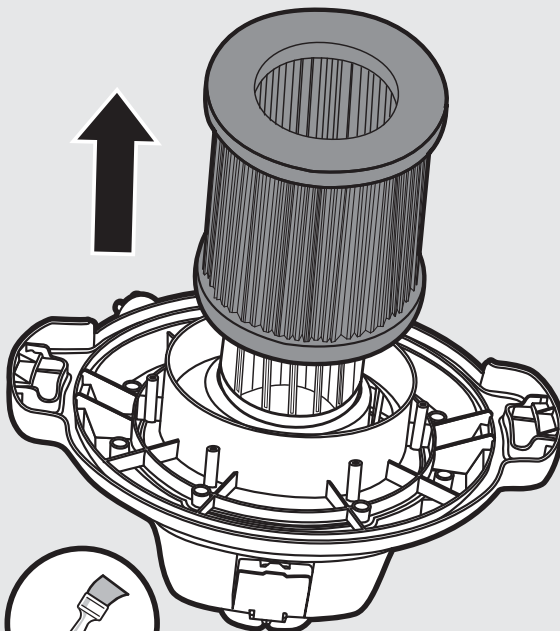

FR Entretien

ES Mantenimiento

PT Serviço

IT Manutenzione

EL Συντήρηση

PL Konserwacja

KZ Техникалық қызмет көрсету

UK Догляд

RO Întreținere

EN Maintenance

RU Уход

C

3

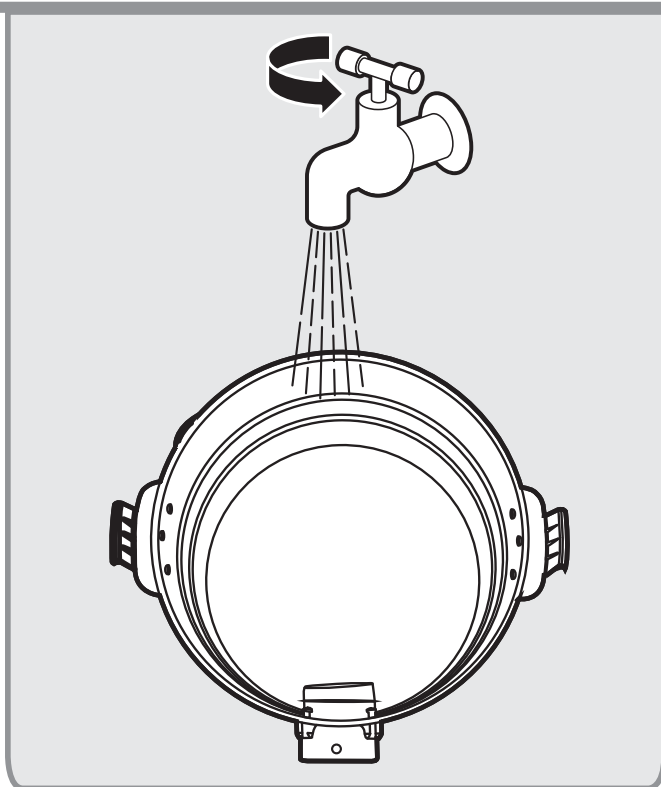
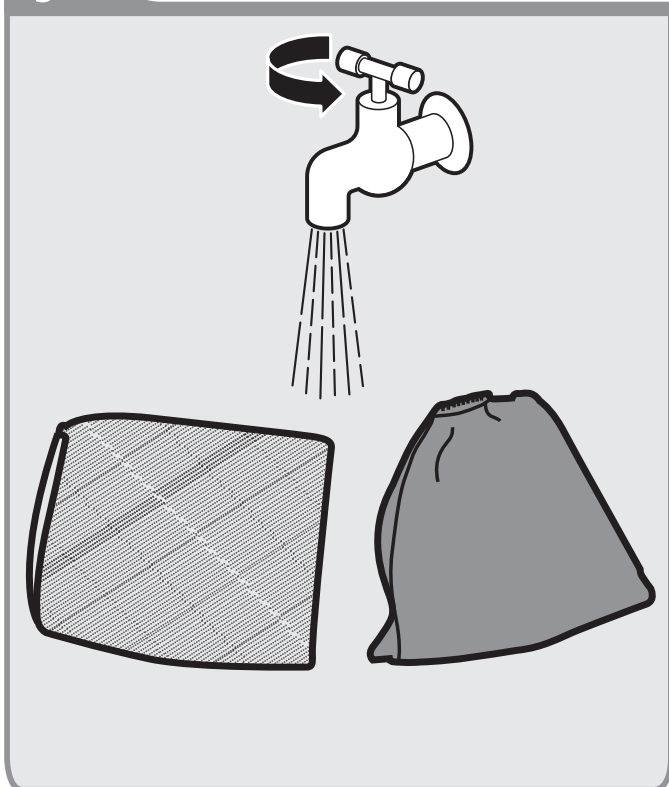

4

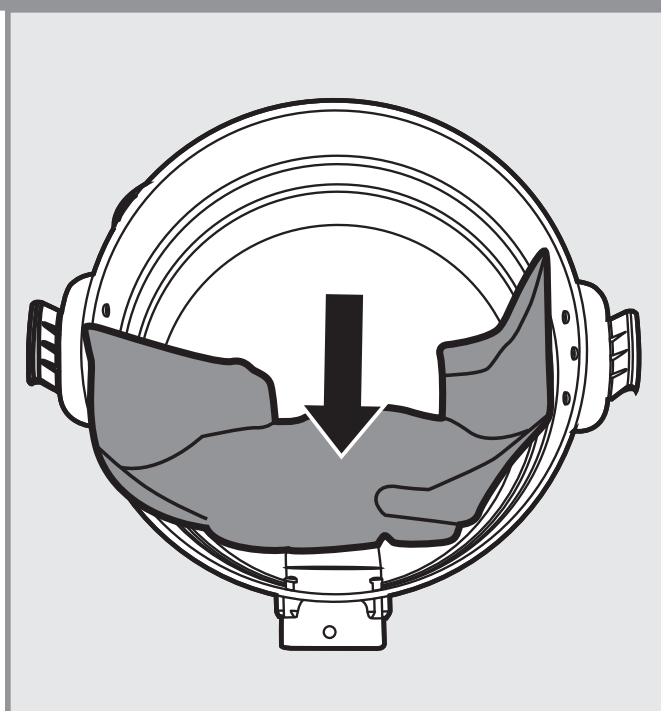
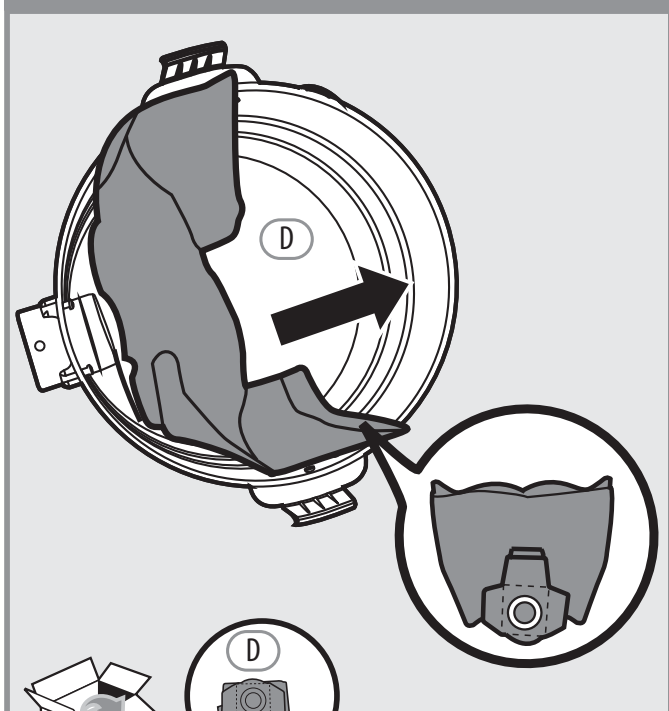

D

FR Hivernage

EL Αποθήκευση το χειμώνα

RO Păstrare pe perioada iernii

ES Durante el invierno

PL Przechowywanie

EN Winter storage

PT Preparação para o inverno

KZ Қысқы уақытта сақтау

RU Зимний период

IT Rimessaggio

UK Зимовий період

1

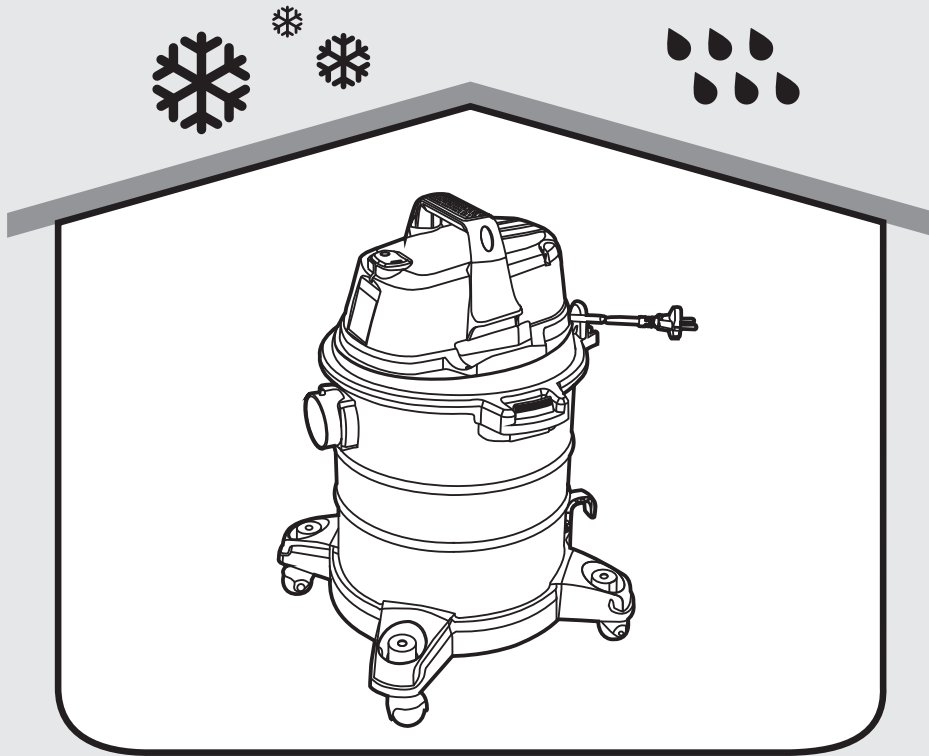

N° de série/N.º de serie/N.º de série/N. di serie/Αρ. σειράς/Nr
serijnу/Сериялық №:/ Серийный номер : /Серійний №/Nr. de serie/Serial No:
204505 00 DDMMYY XX PПPРPР

* Garantie 2 ans / 2 años de garantía / Garantia de 2 anos /
Garanzia 2 Anni / Εγγύηση 2 ετών / 2 lata gwarancji /
Кепілдік 2 жыл / Гарантия 2 года / Гарантія 2 років / Garantie 2 ani /
2-years guarantee



FR ADEO Services - 135 Rue Sadi Carnot - CS 00001
59790 RONCHIN - France

KZ ЛЕРУА МЕРЛЕН ВОСТОК АҚБ, 140031, Мәскеу облысы,
Мытищинский ауданы, Мытищи қаласы,
Осташковское шоссе-1, РЕСЕЙ

UA ТОВ «Леруа Мерлен Україна»,
вул. Полярна 17а, м. Київ 04201, Україна

RU ООО ЛЕРУА МЕРЛЕН ВОСТОК, 141031, Московская область,
Мытищинский район, г. Мытищи, Осташковское шоссе,
д.1, РОССИЯ

Made in P.R.C 2018