

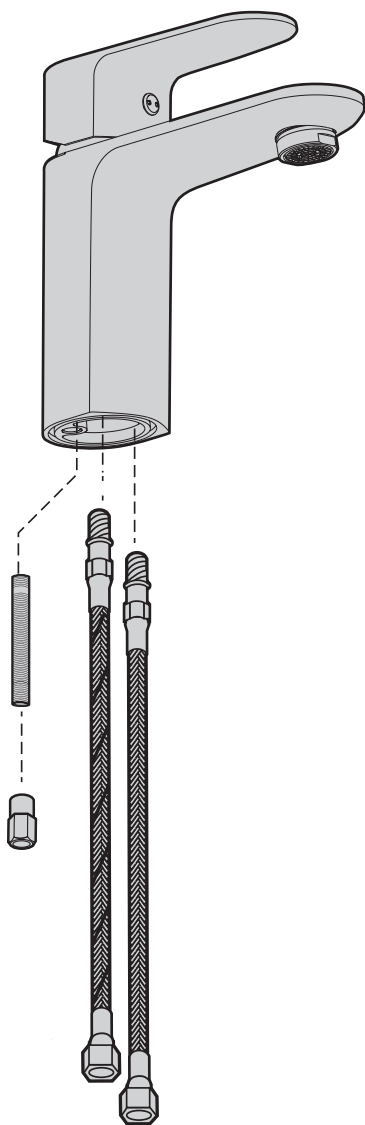

KOTA



- FR** Notice de Montage, Utilisation, Entretien
- ES** Instrucciones de Montaje, Utilización y Mantenimiento
- PT** Instruções de Montagem, Utilização e Manutenção
- IT** Istruzioni per il Montaggio, l'Uso e la Manutenzione
- EL** Εγχειρίδιο συναρμολόγησης, χρήσης και συντήρησης
- PL** Instrukcja Montażu, Użytkowania i Konserwacji
- RU** Руководство По Сборке и Эксплуатации
- UK** Керівництво По Збірці і Експлуатації
- RO** Manual asamblare, utilizare și întreținere
- EN** Assembly - Use - Maintenance Manual

3276000246350



2016-09

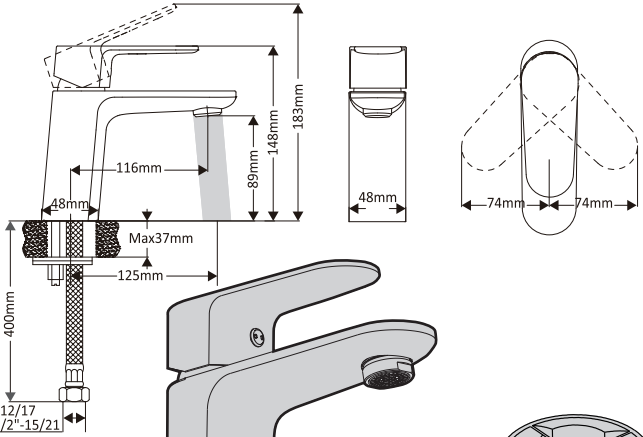
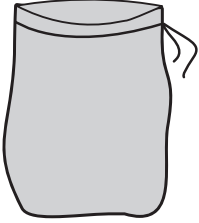

B

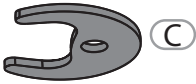

C



D

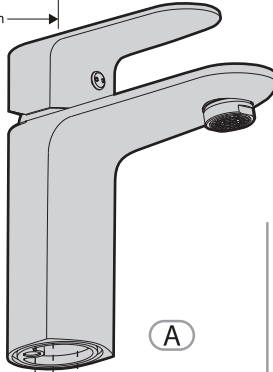

A

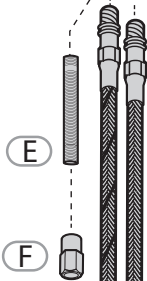

E

F

G

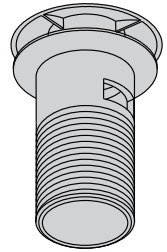

H

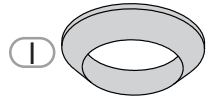

I

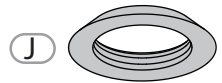

J

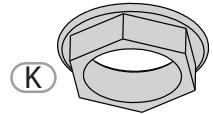

K

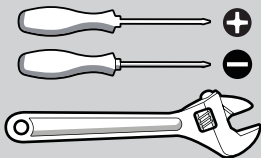
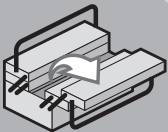

PH

-

2.5mm

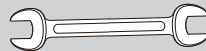

11



45'





Observez / Atención / Aviso / Osservare / Προσέξτε / Przestrzegać / Соблюдайте правила техники безопасности /
Дотримуйтеся правил техніки безпеки / Respectați / Observe



Nettoyage / Limpieza / Limpeza / Pulizia / Καθαρισμός / Czyszczenie / Чистка / Очищення / Curățare / Cleaning



Eau claire / Agua limpia / Água limpa / Acqua pulita / Καθαρό νερό / Czysta woda / Чистая вода / Чиста вода /
Apă curată / Clean water



Sans solvant / Sin disolvente / Sem solventes / Senza solventi / Χωρίς διαλυτικά / Bez rozpuszczalnika / Без растворителя /
Без розчинника / Fără solvent / Solvent-free



Attendre / Espera / Esperar / Attendere / Αναμονή / Zaczekać / Режим ожидания / Режим очікування /
Așteptare / Wait



Maintenance / Mantenimiento / Manutenção / Manutenzione / Σέρβις / Utrzymanie / Техническое обслуживание /
Технічне обслуговування / Menținanță / Maintenance

Notes / Observaciones / Notas / Note / Σημειώσεις / Notatki / Примечания / Примітки / Note / Notes

1

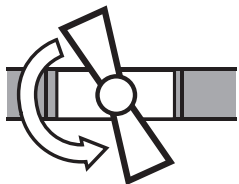

ON

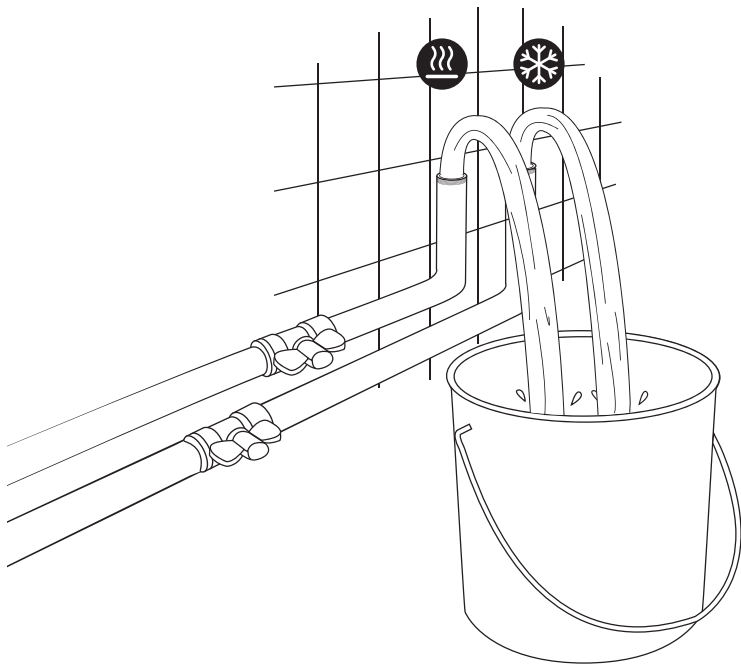

3

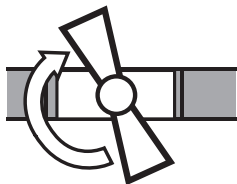

OFF



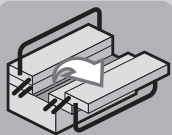
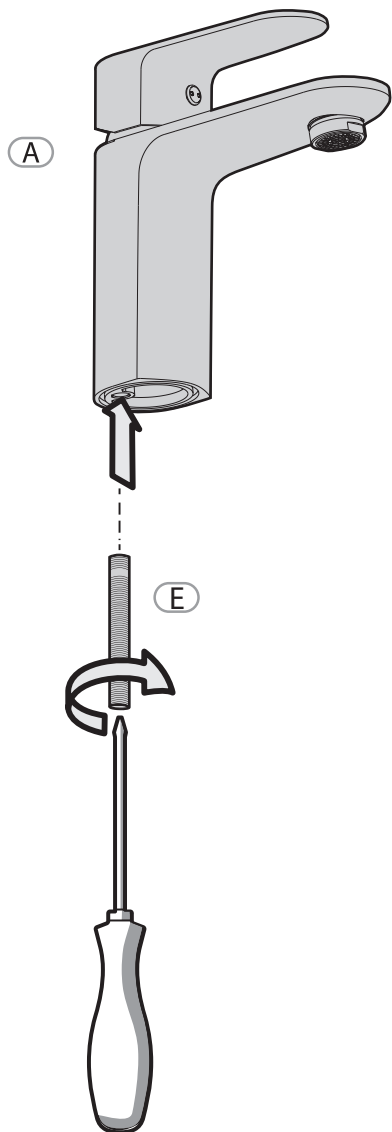

(E)

3

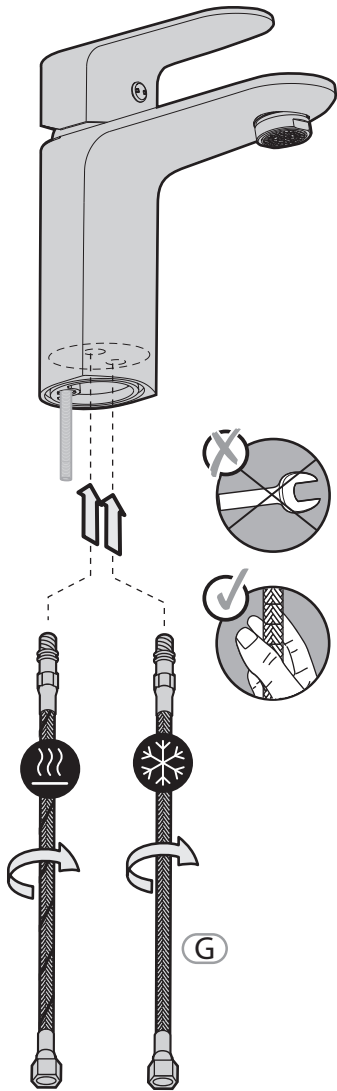

4

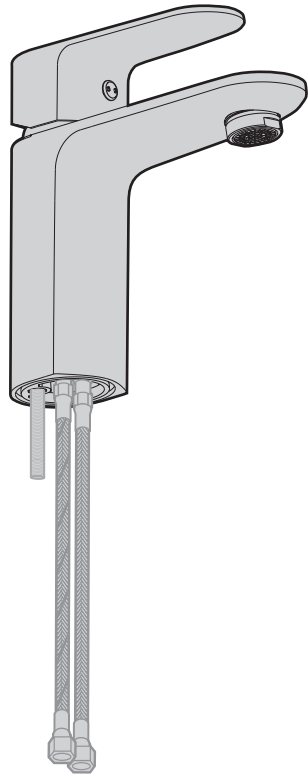

G



5a

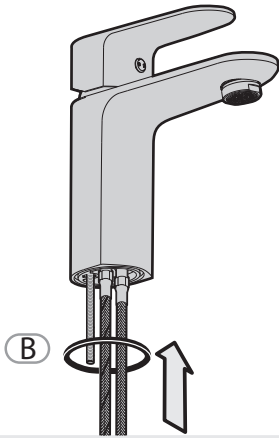

5b

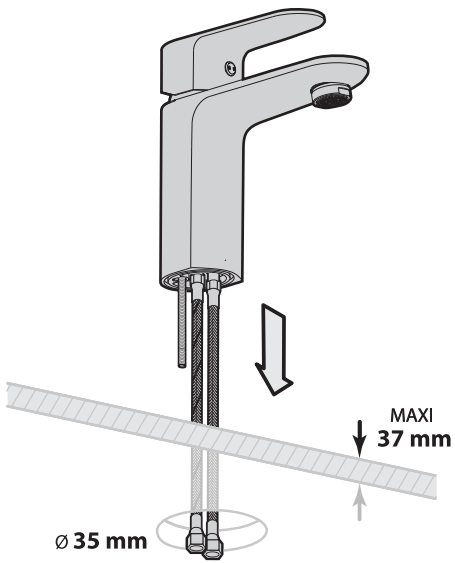

6

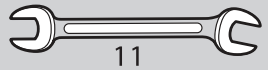
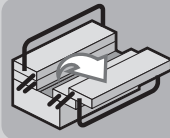
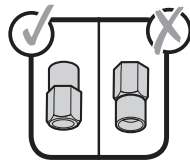
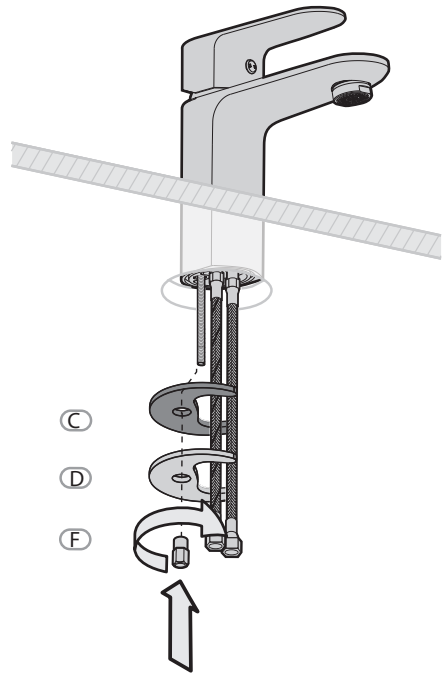

11

B



C



D



F



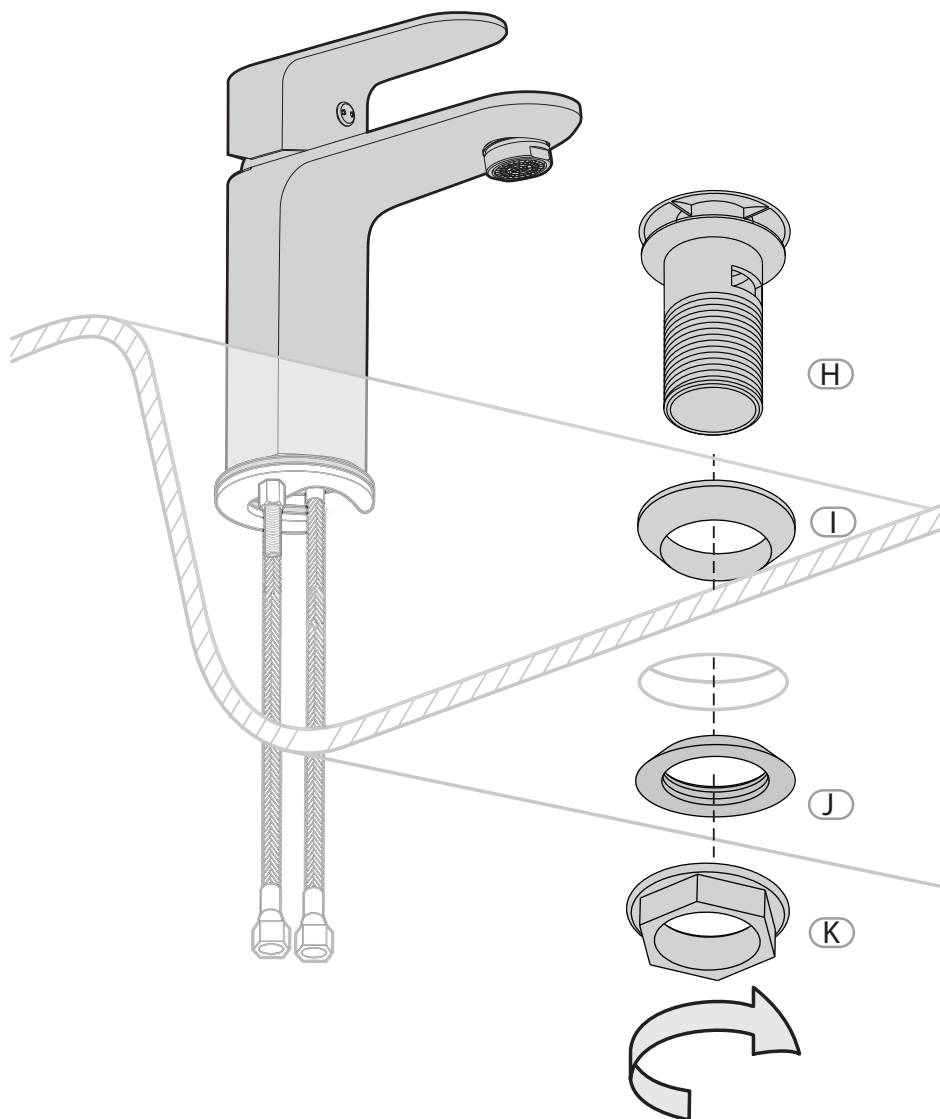

H

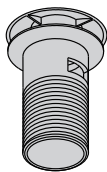

I

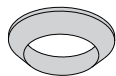

J



K

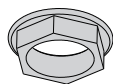

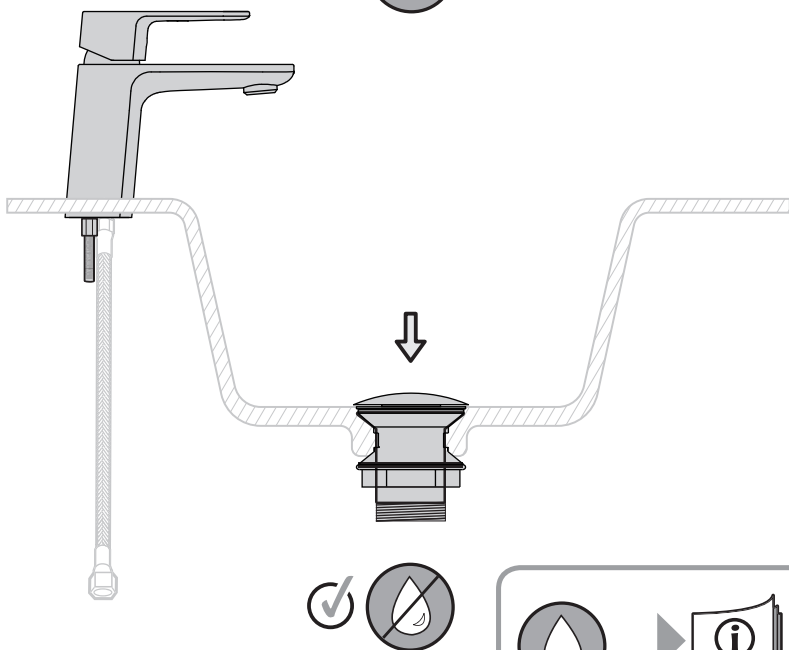
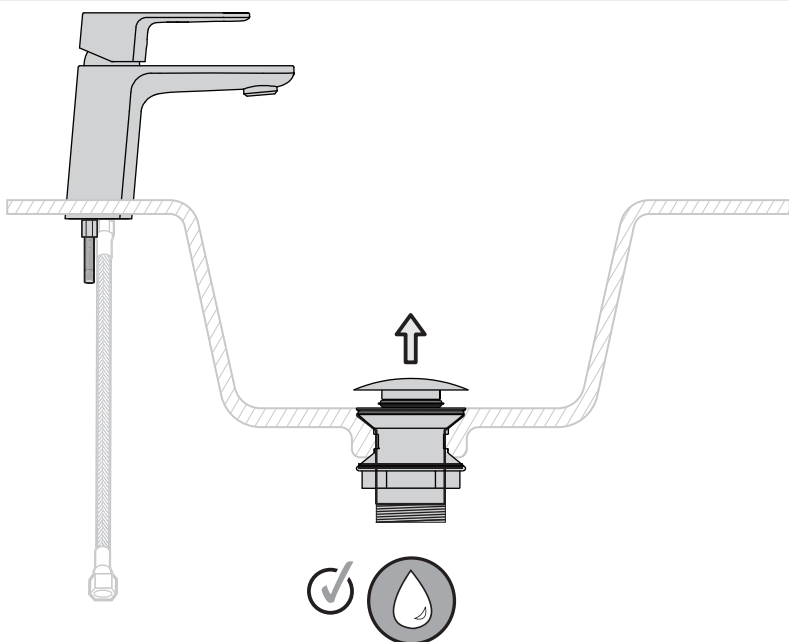

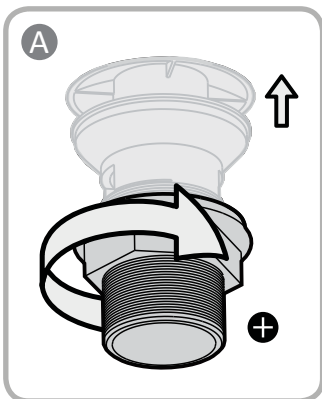
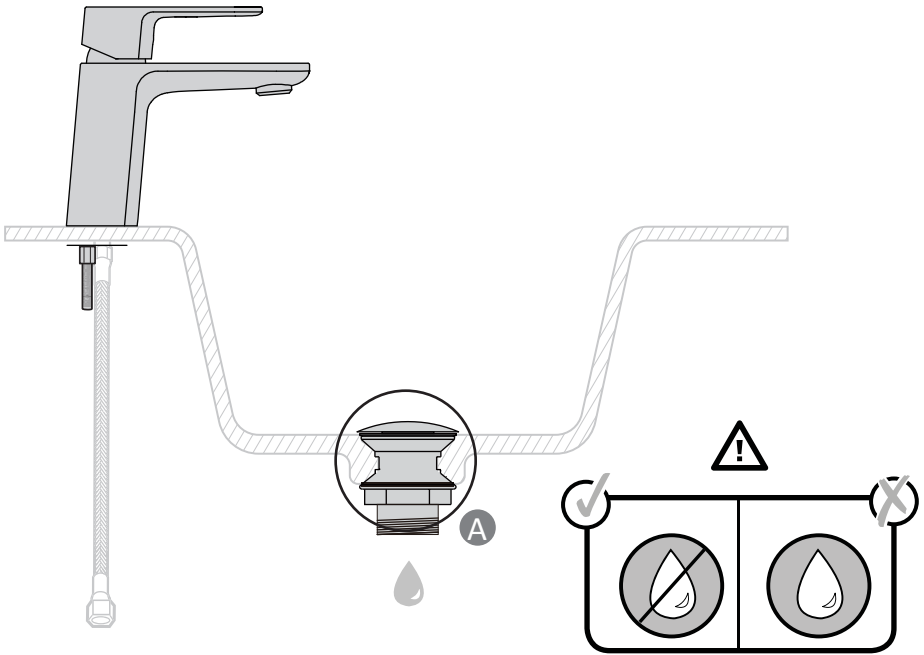

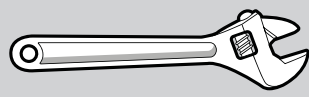
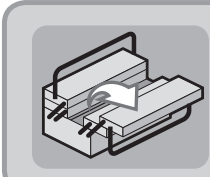
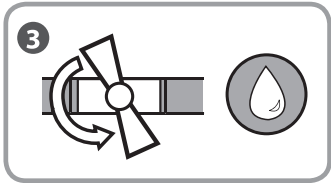
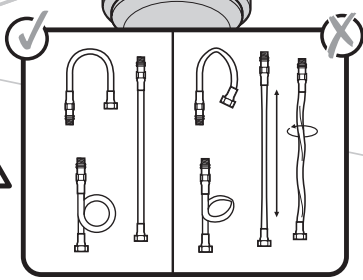
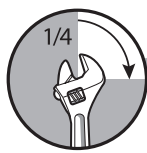
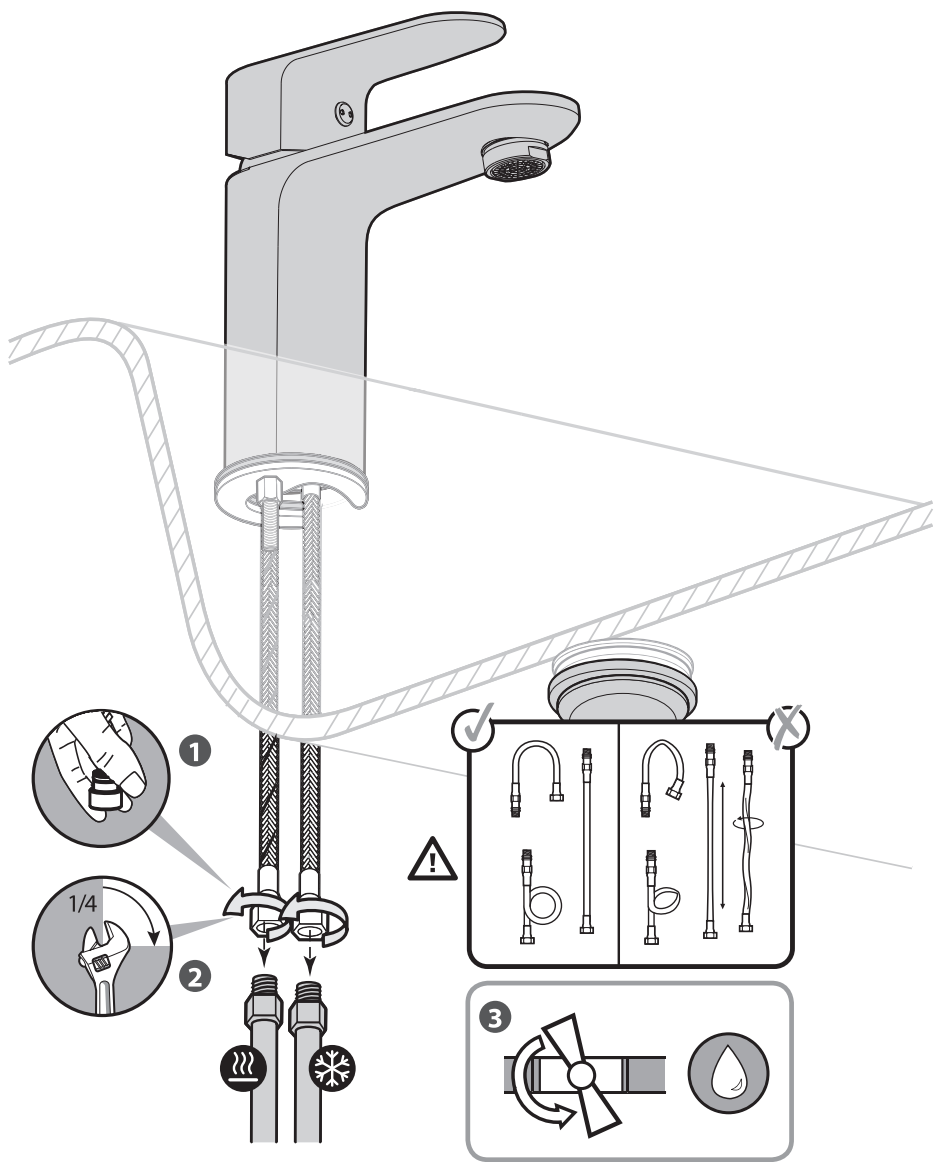

Utilisation eau chaude-eau froide / Utilización agua caliente-agua fría / Utilização água quente-água fria / Uso acqua calda-acqua fredda / Χρήση ζεστού-κρύου νερού / Użytkowanie zimnej wody-gorącej wody / Использование горячей воды - холодной воды / Використання гарячої / води - холодної води / Utilizare apă caldă-apă rece / Using hot and cold water

A

1

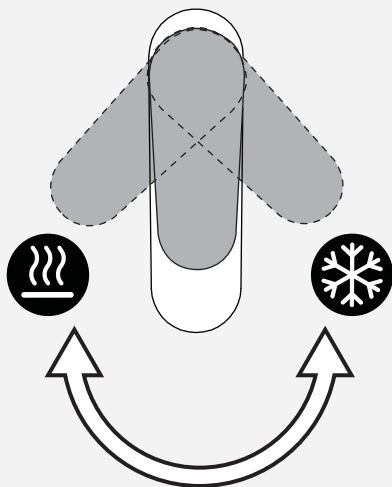
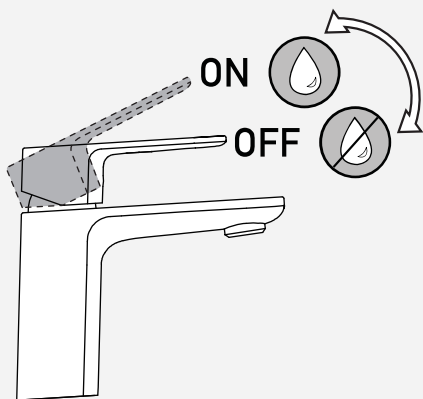

B

Changement de cartouche / Cambio de cartucho / Mudança de cartucho / Cambio cartuccia
Αλλαγή φυσιγγίου / Wymiana wkładu / Смена картриджа / Заміна картриджа / Schimbare
cartuș / Replacing the cartridge

1

⚠️ 👁️

✓

OFF

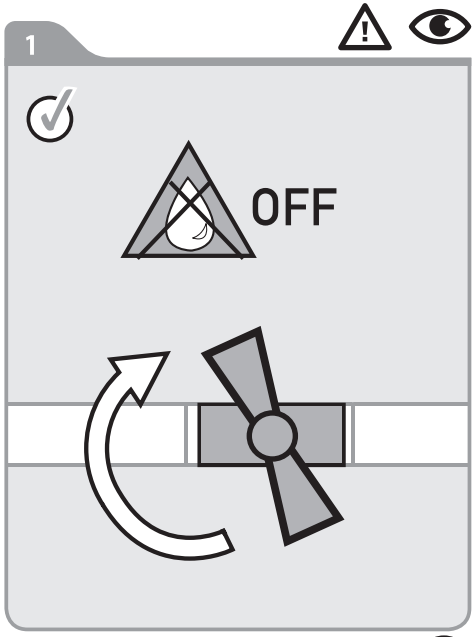

2

🔧

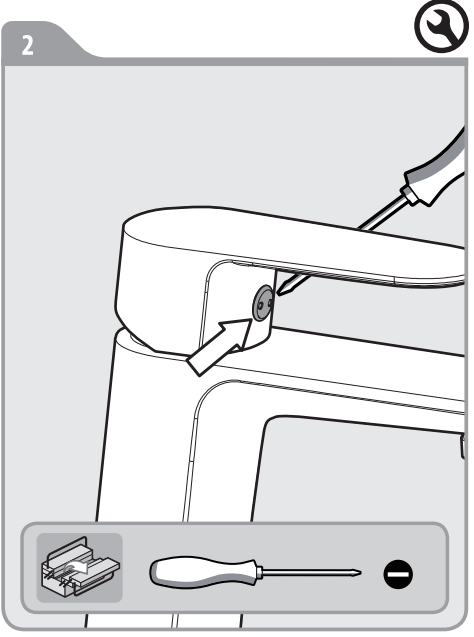

3

🔧

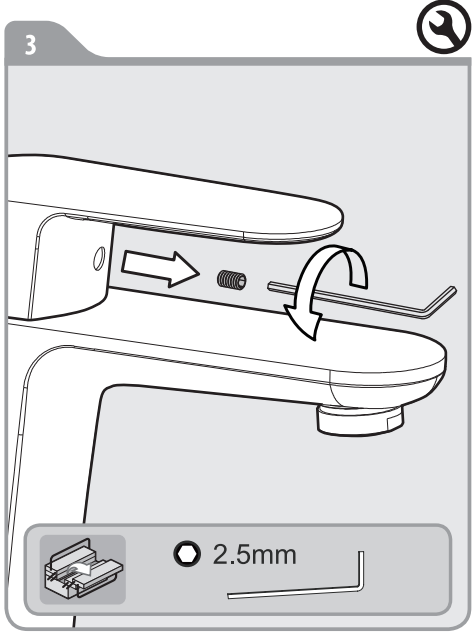

4

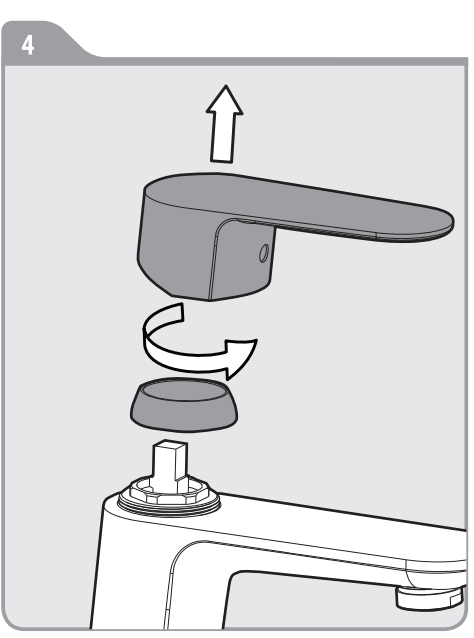

Changement de cartouche / Cambio de cartucho / Mudança de cartucho / Cambio cartuccia /
Αλλαγή φουσιγγίου / Wymiana wkładu / Смена картриджа / Заміна картриджа / Schimbare
cartuş / Replacing the cartridge

B

5

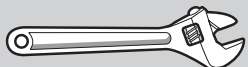
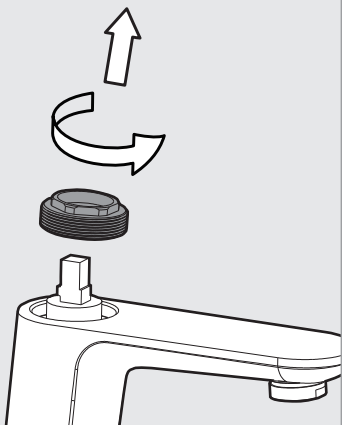

6

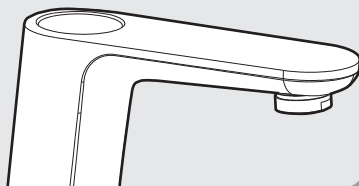
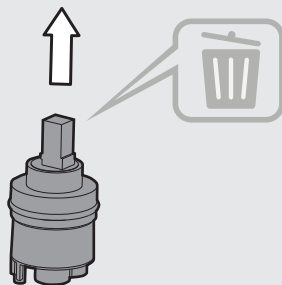

7

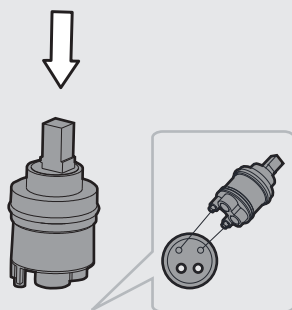

8

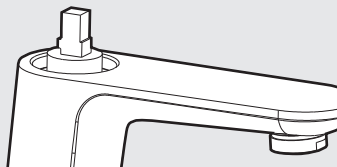
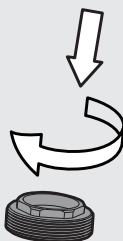

B

Changement de cartouche / Cambio de cartucho / Mudança de cartucho / Cambio cartuccia
Αλλαγή φυσιγγίου / Wymiana wkładu / Смена картриджа / Заміна картриджа / Schimbare
cartuş / Replacing the cartridge

9

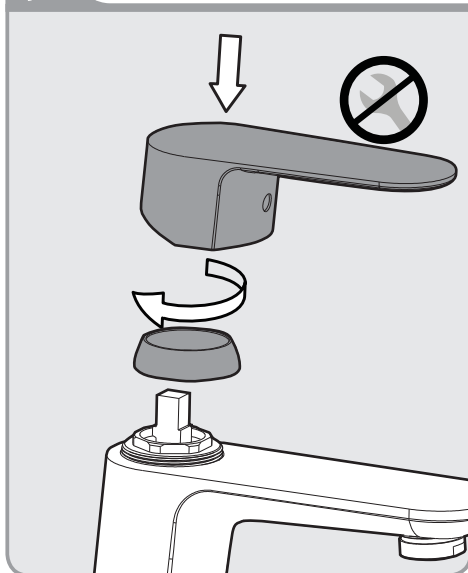

10

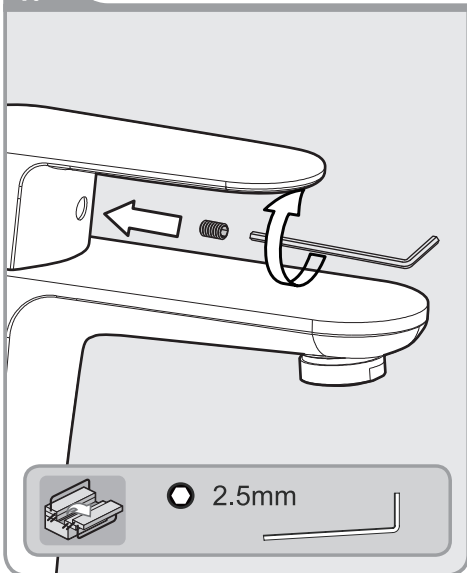

11

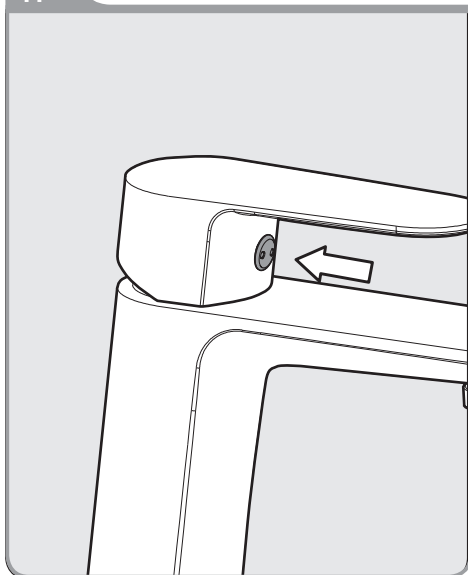

12

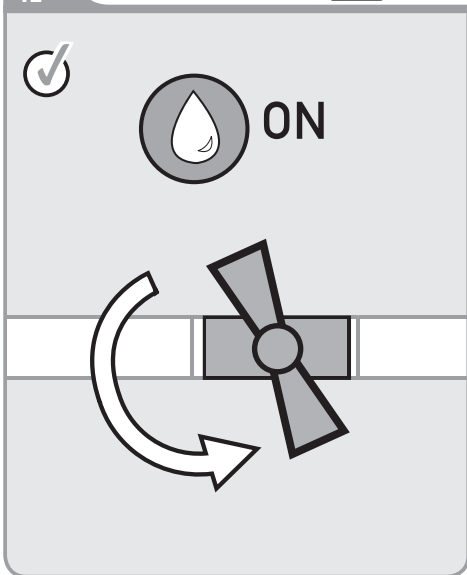

Changement de mousseur / Cambio de aireador / Mudança de arejador / Cambio rom-
pígetto / Αλλαγή αεράτορα / Wymiana perlatora / Смена аэратора / Заміна аератора /
Schimbare aerator / Replacing the aerator

C

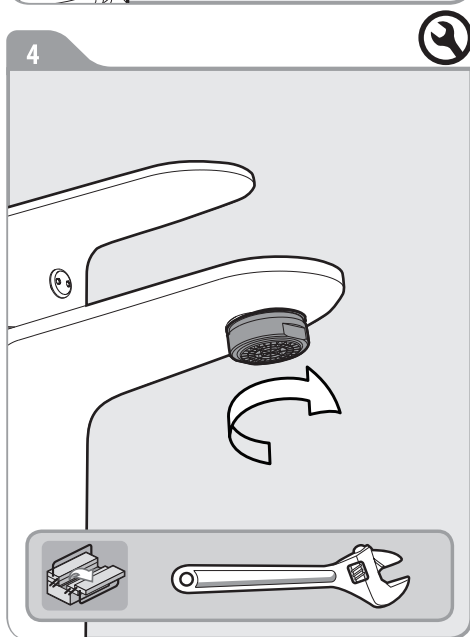
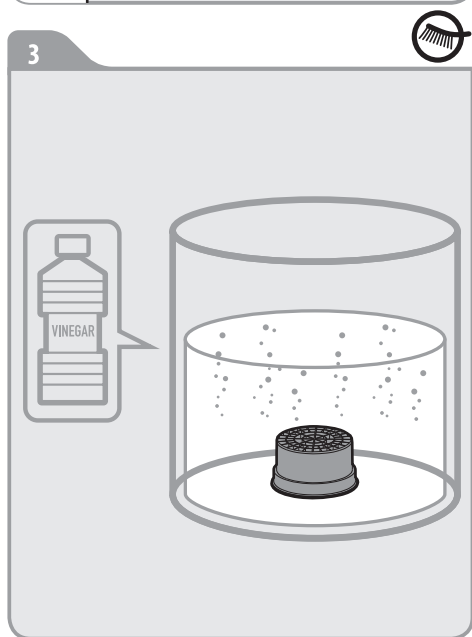
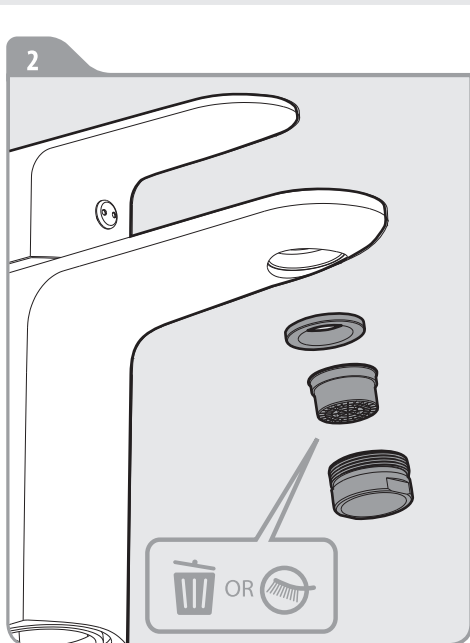
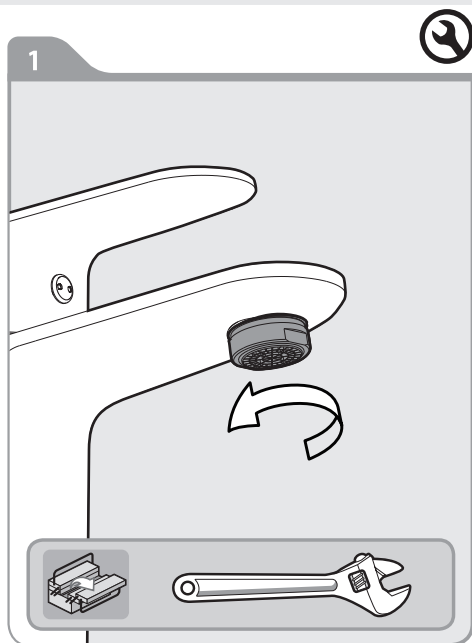

D

Changement de flexibles / Cambio de flexibles / Mudança de flexíveis / Cambio flessibili / Αλλαγή λάστιχων / Wymiana wężyków instalacyjnych / Смена гибкого шланга для смесителя / Заміна гнучкого шланга для змішувача / Schimbare furtune flexibile / Replacing the hoses

1

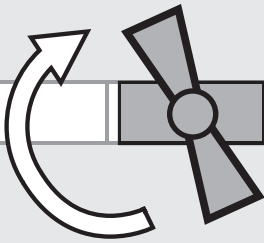
**OFF**

2

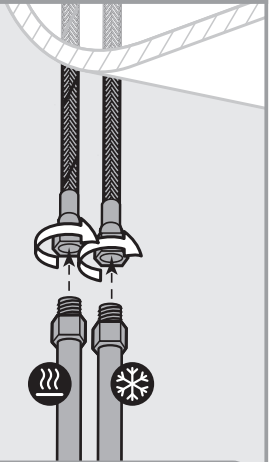

3

**ON**

4

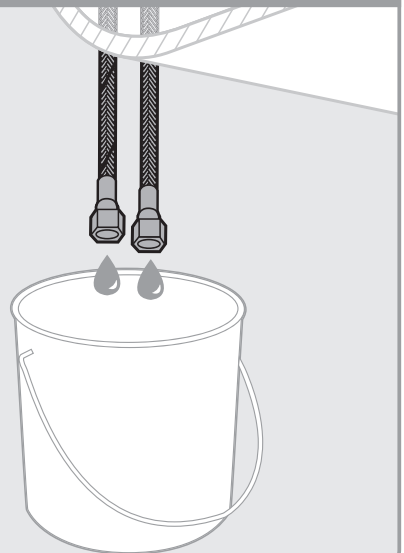

Changement de flexibles / Cambio de flexibles / Mudança de flexíveis / Cambio flessibili /
Αλλαγή λάστιχων / Wymiana wężyków instalacyjnych / Смена гибкого шланга для смесителя
/ Заміна гнучкого шланга для змішувача / Schimbare furtune flexibile / Replacing the hoses

D

5

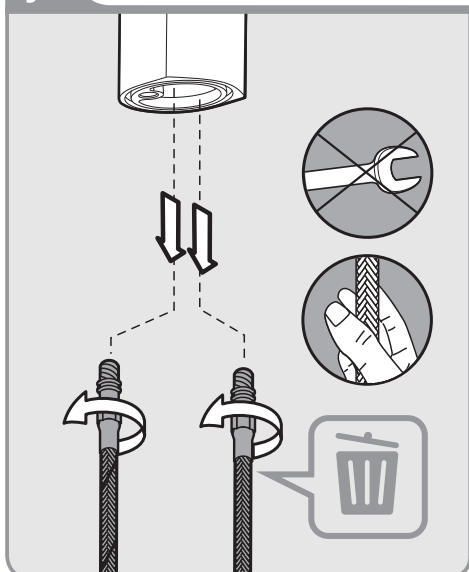

6

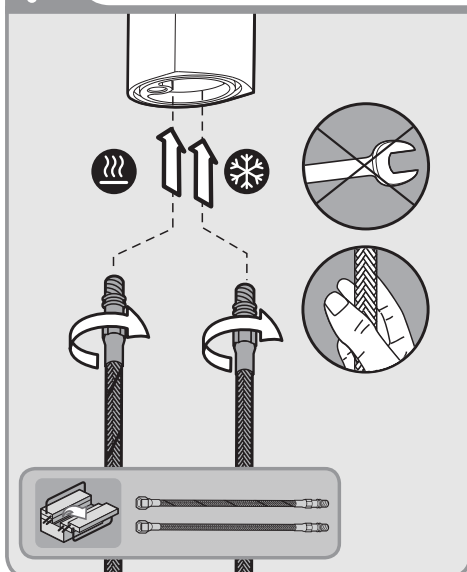

7

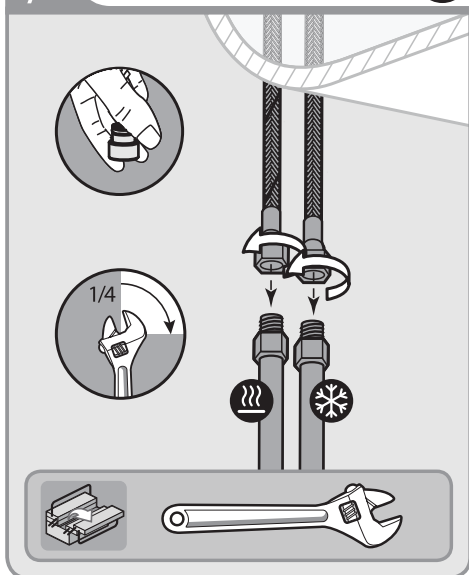

8

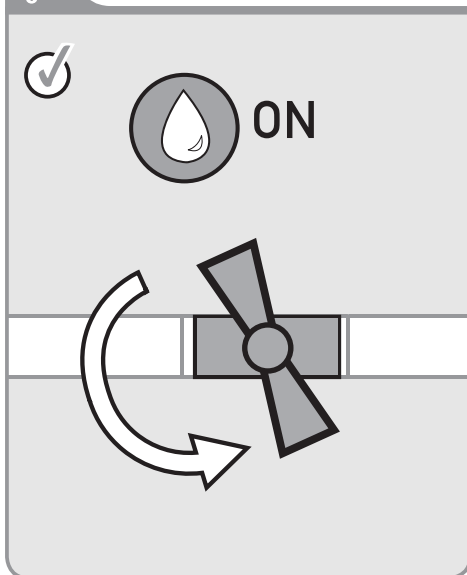

* Garantie 5 ans / Garantía 5 años / Garantia 5 anos / Garanzia 5 anni
Εγγύηση 5 ετών / Gwarancja 5 lat / 5 летняя / 5-річна гарантія
5 ani garanție / Guarantee 5 years

ADEO Services
135 Rue Sadi Carnot
CS 00001
59790 RONCHIN - France

ТОВ «Леруа Мерлен Україна»,
вул. Полярна 17а, м. Київ
04201, Україна

ООО ЛЕРУА МЕРЛЕН ВОСТОК,
141031, Московская область,
Мытищинский район, г. Мытищи,
Осташковское шоссе, д.1, РОССИЯ

Made In P.R.C. 2016